

FLUX

The magazine for bulk ingredients technology

VERSATILITY IS KEY



Clextral Success Story
Extrusion of meat substitutes

8 hours with ...
the ShowTruck

BRUNO DAUTZENBERG
CEO
Brabender Technologie

DR. GÜNTER KUHLMANN
CEO
Brabender Technologie

> editorial



Dear business partners and colleagues,

What's important to you in terms of the food you eat? During the pandemic, many people have reflected on what they would like to change – and on making better and more conscious dietary choices. This has led to a new appreciation of food and the people who produce it. However, we still take it for granted that we have a wide variety of food choices available to us at any time.

The food industry is as diverse as its applications. Modern production lines must be flexible to easily adapt to product changeover and lot size while maintaining consistent product quality. Our Hygienic Design feeder systems are ideally suited to fulfill these requirements. One of the main considerations for our new modular concept design “generation 2.0” was to meet these demands, you can read more about this starting on page 14.

On page 4 you can explore more about this issue's main topic “New Food” in the lead article “Pretty flexible”. Also featured is the success story that profiles our French partner Clextral and looks at the exciting food trend “extrusion of meat substitute products” starting on page 10.

We wish you an inspiring read.

Bruno Dautzenberg and Günter Kuhlmann



IMPRINT
FLUX is the magazine for bulk ingredients technology from Brabender Technologie GmbH & Co. KG

Publisher:
Brabender Technologie GmbH & Co. KG
Kulturstrasse 49
47055 Duisburg, Germany
Phone: +49 203 9984-0
email@brabender-technologie.com

Editorial Team:
Brabender Technologie GmbH & Co. KG,
C&G: Strategische Kommunikation GmbH
www.wir-verstehen-technik.de

Copyright and rights of use of text and photos:
Brabender Technologie GmbH & Co. KG
www.brabender-technologie.com

Edition no. 12
Release date: August 2021

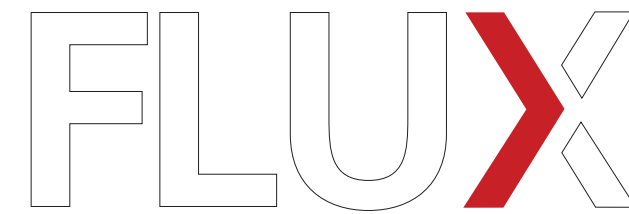

- > profund / 04 Food industry
Versatility is key
- > usus / 10 Clextral Success Story
Extrusion of meat substitutes
- > machina / 14 New equipment generation 2.0
If it's modular you want - you got it!
- > machina / 18 SiloTray
Keeping the flow
- > lux / 22 Series: 8 hours with... the ShowTruck
It's Showtime
- > lux / 24 Our representative in the Northeast USA
MassFlow Solutions
- > lux / 26 News
Brief news items from around the world
- > lux / 27 Technical column
How sealed is your process?

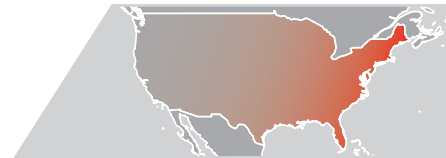



Food industry

Versatility is key

> Quality, safety, increased uptime and tailored products at affordable prices, that is what characterizes modern-day food production. Increasingly, more specific consumer needs and an awareness of food quality call for production processes that can be quickly adapted to changing requirements.

One in seven German manufacturing companies are involved in food production. The food industry is Germany's fourth largest industrial sector in terms of revenue. Sustainability and consumer product awareness are playing an increasingly important role in the supply of premium food. During the Covid-19 crisis this appreciation of ethically sourced food has gained popularity.

"The pandemic has greatly changed the entire food world," says Hanni Rützler, one of Europe's leading food trend researchers. Every year she publishes >

the 'Food Report' in collaboration with the Zukunftsinstitut. The 2021 report has been heavily influenced by the pandemic. "This crisis has driven innovation and is unleashing new forces to help generate sustainable approaches, which will remain effective once the crisis is over. It is making us reflect on what we want to change in order to make our food system more resilient and our culinary culture more sustainable and enjoyable." According to Hanni Rützler, some trends have gained considerable speed, while others have slowed down drastically in the last year.

Variety is the future of food

Above all, the wide variety of different foods available means that

diversity will have a major role to play in the future of global food supply. Currently only 9 percent of plant species account for 66 percent of global crop yields. "This massive reduction down to just a few productive species comes at a high price. It makes us more vulnerable – for example, in terms of soil quality. This is highlighted whenever there is another dry summer or we have to combat pests using chemical agents," Rützler warns. "To be able to guarantee the global food supply in future, we must focus on crop and livestock diversity. Biodiversity is clearly the future." Her recommendation is the food production industry should focus on additional food alternatives. In culinary terms

that would make things more exciting anyway.

What are important food trends?

Domestic agriculture and regional supply of food have become more important to consumers in the last few months. A new appreciation of food and those who produce it has emerged. The new desire is for healthy food choices to not only taste good, but also to be produced sustainably and equitably. When it comes to animal products, animal welfare is taking on greater importance in livestock farming. The food report by the Federal Ministry of Food and Agriculture (BMLE) highlights that people are prepared to pay more for equitably farmed animal products.



THE MOST EXCITING FOOD TRENDS FROM GERMANY IN 2020

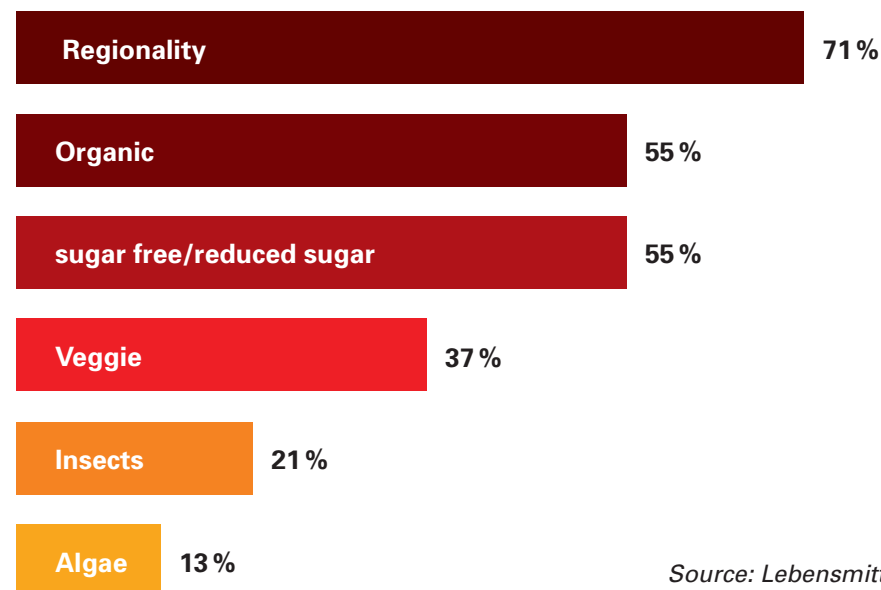

Source: Lebensmittelzeitung (LZ), Copyright: Statista 2020

This consumer trend towards a healthy diet is also having an impact on food retailers. In a survey by Lebensmittelzeitung (LZ) "The most exciting food trends from a retail perspective", retailers rate regional products, certified organic, and sugar-free foods as being the most important current food trends. Of secondary interest were unusual product groups such as insects and seaweed.

Flexitarians are gaining ground

Another important change in dietary habits is that increasingly, people are consciously giving up meat. According to a survey conducted by the Federal Ministry of Food and Agriculture, nearly half of all respondents have purchased

vegetarian or vegan alternatives to animal products at least once or occasionally. 55 percent of respondents describe themselves as flexitarians, i.e., meat eaters, who consciously forgo meat periodically. In particular, men are eating less meat.

"Feeders used in the food industry must be capable of being very thoroughly cleaned. That is why we consider Hygienic Design in our product development. This means that all components are easily accessible – for example screws and screw tubes feature quick-release fasteners."

Klaus Plien, Food Industry Sales Manager Brabender Technologie

There are many different reasons for this trend. These include climate protection, animal welfare, good taste or simply out of curiosity. In the first quarter of 2020, sales of meat substitute products increased by a remarkable 37 percent compared with the same period in 2019. Relative to meat industry sales, the value of meat substitute product output is still comparatively small. The trend is clear: plant-based burgers and meat substitutes are finding their way into German shopping carts more frequently.

Are insects the future?

The world's population is set to grow to 9.7 billion people by 2050 according to United Nations estimates. In order to feed them all sustainably, we require an additional 250 million tonnes of protein a year – 50 percent more than is currently produced. Therefore, alternative sources of protein, such as legumes or seaweed, are attracting significant attention. Insects represent a promising opportunity to obtain high-grade protein on a sustainable basis as they are easy to breed and can be fed on organic waste. >

Easy accessibility of all components for cleaning



Peas instead of Pecorino

Increasingly, there are more cheese alternatives. To date they have been soya-based and contain additives intended to come as close as possible to replicating the flavor and texture of real cheese. In contrast, the Fraunhofer Institute for Process Engineering and Packaging IVV's "KERBSE" project is focusing on the native pea and traditional methods of cheesemaking. The protein in this legume is suitable for producing cheese-like structures. It is easily soluble and has emulsifying properties. A pea slurry is fermented and then matured. These processes make additives unnecessary and reduce the beany flavor of the pea. To enable this cheese substitute to reach supermarket shelves quickly, the Institute is

partnering with small dairies and makers of vegan products.

Is our food safe?

Ongoing scandals involving meat have demonstrated the importance of food safety. Perhaps that is why consumers are increasingly turning to meat substitute products like vegetarian spreads, soya patties or tofu in their diets.

We expect the products offered to be safe and healthy as safety is a fundamental element in food production. Manufacturers and retailers bear responsibility for this issue and are strictly monitored by government food inspectors. In the globalized world the food industry faces pressure to enhance its products and processes, reduce cycle times, and minimize

costs to remain competitive. Despite these challenges, food safety can never be compromised.

Production flexibility matters

We take for granted that we always have a wide variety of different food choices. With increasing product diversity, product lifecycles and production quantities are reduced. Modern production lines require quick product changeover to accommodate multiple recipes and smaller lot sizes. Modular and flexible design enables manufacturing lines to be quickly adapted to new product requirements. It is important that food processing equipment is quick and easy to clean as every minute of plant downtime is costly. It is a top priority to minimize plant downtime.

Hygienic Design for easy and quick cleaning

The food industry has strict hygiene and documentation standards that must be reliably complied with. Our customers can always depend on the fact that Brabender Technologie's feeding technology is manufactured to comply with food safety standards. Klaus Plien, Food Industry Sales Manager, explains: "Feeders used in the food industry must be capable of being very thoroughly cleaned. That is why we consider Hygienic Design in our product development. This means that all components are easily accessible – for example screws and screw tubes feature quick-release fasteners." In addition there are no exposed threads in ingredient contact zones, and smooth stainless-steel surfaces are used preventing contamina-

The Fraunhofer IVV's KERBSE research project is developing dairy-free cheese alternatives made from pea protein.



© Fraunhofer-Institut für Verfahrenstechnik und Verpackung IVV

i FEEDING FOODS

Feeding raw materials used in food production is a delicate task as these materials are prone to breakage. Manufacturing food products require stringent quality control, sanitary conditions, highly accurate feeding according to the formulation. Our special Hygienic Design equipment allows safe production of dry, moist and liquid foods of any consistency.

You will find interesting facts and details on our bulk ingredient solutions for food applications in our interactive digital brochure:



tion. To reduce air born dust and accumulation, we use motors without cooling fans or fins.

Brabender Technologie feeders feature industry leading cleanability that significantly reduces downtime and facilitates quick product changeovers. Only FDA- and 1935/2004-compliant materials are used to make Hygienic Design feeders. For example, polyurethane components are food-compatible and feature a blue finish for better visual identification. As a member of the European Hygienic Engineering & Design Group (EHEDG), Brabender Technologie regularly receives updated information about current changes and guidelines. This enables us to constantly innovate our Hygienic Design equipment to the constant evolving sanitary standards.

From trend to technology

Klaus Plien emphasizes: "By listening to our customer feedback and monitoring food industry trends, we can collaboratively develop new solutions for the industry."

CLEXTRAL and Brabender Technologie

Read about this exciting and successful partnership on the following pages. ■

@ CONTACT

Klaus Plien
Food Industry Sales Manager
Brabender Technologie

Phone: +49 203 9984-0
Email: kplien@brabender-technologie.com



Clextral Success Story

Extrusion of meat substitutes

Meat substitutes could be part of the solution for feeding a rapidly growing world population. Clextral, a French manufacturer of food extrusion equipment, who has been in this market for many years has recently successfully partnered with Brabender Technologie.

One of the greatest challenges of the 21st century will be to feed the growing world population while protecting the environment and animal welfare. Global meat consumption has more than doubled in the last 50 years. This substantial increase in

industrial livestock production has had a serious environmental impact and raises ethical questions in relation to animal welfare. In addition, excessive meat consumption has a negative impact on human health.

"The end products of the High Moisture Extrusion Cooking process have the potential to help to feed the growing world population on a sustainable basis in the future."

Emmanuel Lavocat,
food extrusion process engineer at Clextral



Clextral uses twin screw extrusion to produce a new generation of meat substitute.

Flexitarians and meat substitutes

These worrisome developments have given rise to a new food trend: a conscious reduction in personal meat consumption. Flexitarians regularly eat meat but are mindful of nutrition and the environment. They try to incorporate healthy, plant-based, protein-rich alternatives to traditional meat products in their diets. Plant-based meat substitutes resemble real meat in terms of flavor, appearance, and texture, but consist of plant-based proteins. These meat substitutes are rich in protein, fiber and nutrients and contain highly effective essential amino acids, that are cholesterol-free, and low in fat. The most important sources of plant-based proteins include wheat gluten, soya beans, peas, lentils, fava beans, chickpeas, green beans, and lupins.

Clextral: the food extrusion expert

Since the late 1990s, Clextral, a French manufacturer of food extrusion equipment, has been working together with food processors and food research centers to develop convenience foods made of fibrated protein products, which consist of extruded fibrous proteins. Jérôme Mottaz, Head of Engineering and R&D at Clextral, explains: "In the past few years, the sales figures for texturized or fibrated vegetable protein in Europe, Asia, America and Australia have increased steadily. Since 2001, we have held a patent for High Moisture Extrusion Cooking (HMEC) – one of the two twin-screw extrusion processes used to manufacture meat substitute products from proteins."

The two extrusion processes

In addition to the High Moisture Extrusion Cooking process, there is also a "dry" process, called TVP. The two extrusion processes differ from one another in terms of the configuration of the extruder and the die used. In the dry extrusion process, Clextral usually feeds a premix made of soya powder or pea concentrate with a protein content of between 50 and 60 percent into the extruder. Using a simple die produces an extrudate with a spongy texture and a low moisture content of 10 to 23 percent at the exit of the extruder die and around 8% at the exit of the dryer post extrusion. After rehydration, the extrudate is ready for consumption at home.



Sources of vegetable proteins from left to right: soybeans, peas and chickpeas.

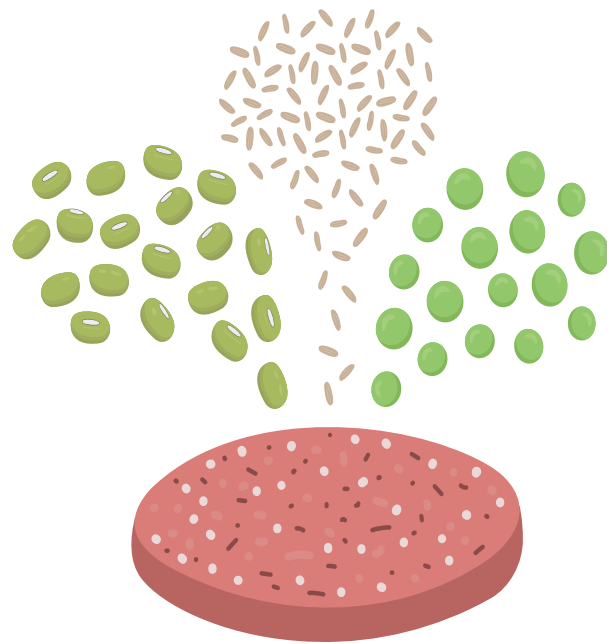

state, proteins are like woolen threads that are interwoven. During the cooking process in the extruder, they are disentangled, unfolded and cut into small pieces. In the die, they are then re-crosslinked to produce even filaments of good quality.”

Cooling die influences texture

A long cooling die is positioned behind the screw-barrel configuration, and it plays a key role in the HMEC process. The setup of its cooling channels, the cross-sectional area and aperture dimensions all have a major impact on the texture and quality of fiber formation. For example, both rough surfaces featuring relatively short, thick, cross-sectionally oriented fibers and smoother surfaces with long, thin, laminar-flow-oriented fibers are feasible. Each of these products is used for specific food applications, for example, as analog chicken strips or analog pulled pork. HMEC creates intermediate products, the structure and texture of which closely resembles the muscles found in meat. Further processing also enables flavor, olfactory and visual features to be added.

Look into the future

“The end products of the High Moisture Extrusion Cooking process have the potential to appeal to consumers, who have previously viewed analog meats with skepticism,” says Emmanuel Lavocat with conviction – and they could help to feed the growing world population on a sustainable basis in the future.

High Moisture Extrusion Cooking

Plant-based raw materials like peas or soya are also used in the HMEC process, although in the form of isolate or concentrate with a higher protein content of 70 to 80 percent. The difference compared to the dry process is that HMEC involves thermomechanical processing – “cooking” – the proteins at temperatures in excess of 120 degrees Celsius and at a high moisture content of 50 to 70 percent, as well as relatively long dwell times. This process enables fiber formation and takes place in a complex screw and barrel configuration within the twin-screw extruder, where the specific screw configuration features a high length to diameter ratio.

Emmanuel Lavocat, food extrusion process engineer at Clextal, describes it as follows: “In their original

“Precision feeding is very important for the whole process.”

FLUX spoke with **Jérôme Mottaz (JM)**, Head of Engineering and R&D, and **Emmanuel Lavocat (EL)**, food extrusion process engineer, both from Clextal, about the partnership with Brabender Technologie and future market trends.



Jérôme Mottaz



Emmanuel Lavocat

FLUX: Mr. Mottaz, what role does feeding play in the manufacturing process?

JM: Industrial food production always involves absolute precision. That is why accurate feeding is very important for the whole process. All ingredients have to be metered into the extruder in precisely measured quantities. The degree of precision applied at the start of the process ultimately influences the quality of the end product. You can always rely on Brabender Technologie’s gravimetric feeders to perform with absolute precision.

FLUX: How do you find the right feeder for each of your customers’ applications?

JM: In our Technical Center in Firminy, we can test the different raw materials or dry mix recipes involved in almost all food applications. Brabender Technologie has provided us with a large number of different gravimetric feeders for our test lab. This provides us with the flexibility to test the required raw materials and specific formulations on different feeders. We can always draw on Brabender Technologie’s expertise and

their technical centers around the world at anytime.

FLUX: What benefits do Brabender Technologie’s feeding systems provide?

EL: Food safety plays an overriding role in food manufacturing. The special Hygienic Design concept employed in Brabender Technologie’s feeders reliably meets that requirement. What we particularly value is that Hygienic Design can be adapted to meet the specific requirements of the customer – from minimum requirements to a very high sanitary standard. In addition, the feeders feature exceptional cleanability and are easy to operate.

FLUX: In which direction might the market for meat substitute products be headed in the future?

EL: Raw material diversity will increase. We are already testing new raw materials, such as chickpeas, fava beans or lentils, which are equally suitable for wet extrusion. However, given

their limited availability on the world market they are still too expensive. This may change in the future as many consumers reject genetically modified products like soya, because of ethical and health concerns.

FLUX: What does that mean in technology development terms?

JM: A major challenge is enhancing performance while maintaining the same level of operability. Our R&D team is already addressing this topic. Product expertise and process know-how are the key issues in creating the best analog meats from various sources of protein.

FLUX: Mr. Mottaz, Mr. Lavocat, many thanks for the interesting conversation!

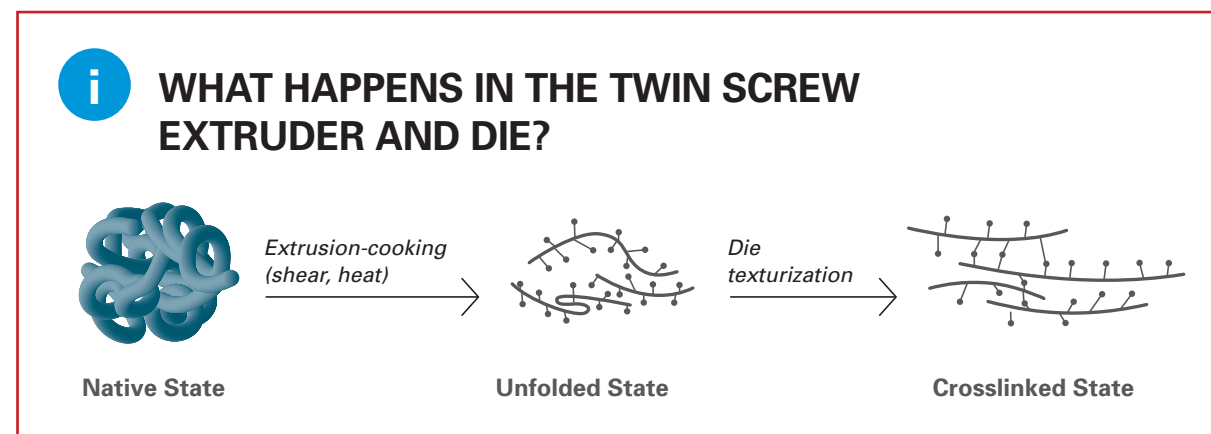

New equipment generation 2.0

If it's modular you want – you got it!

Our next generation 2.0 DDSR40/B and DSR67/B feeders features a modular design providing significant benefits in terms of flexibility, cleaning, sealing and improving changeover time for your production process.

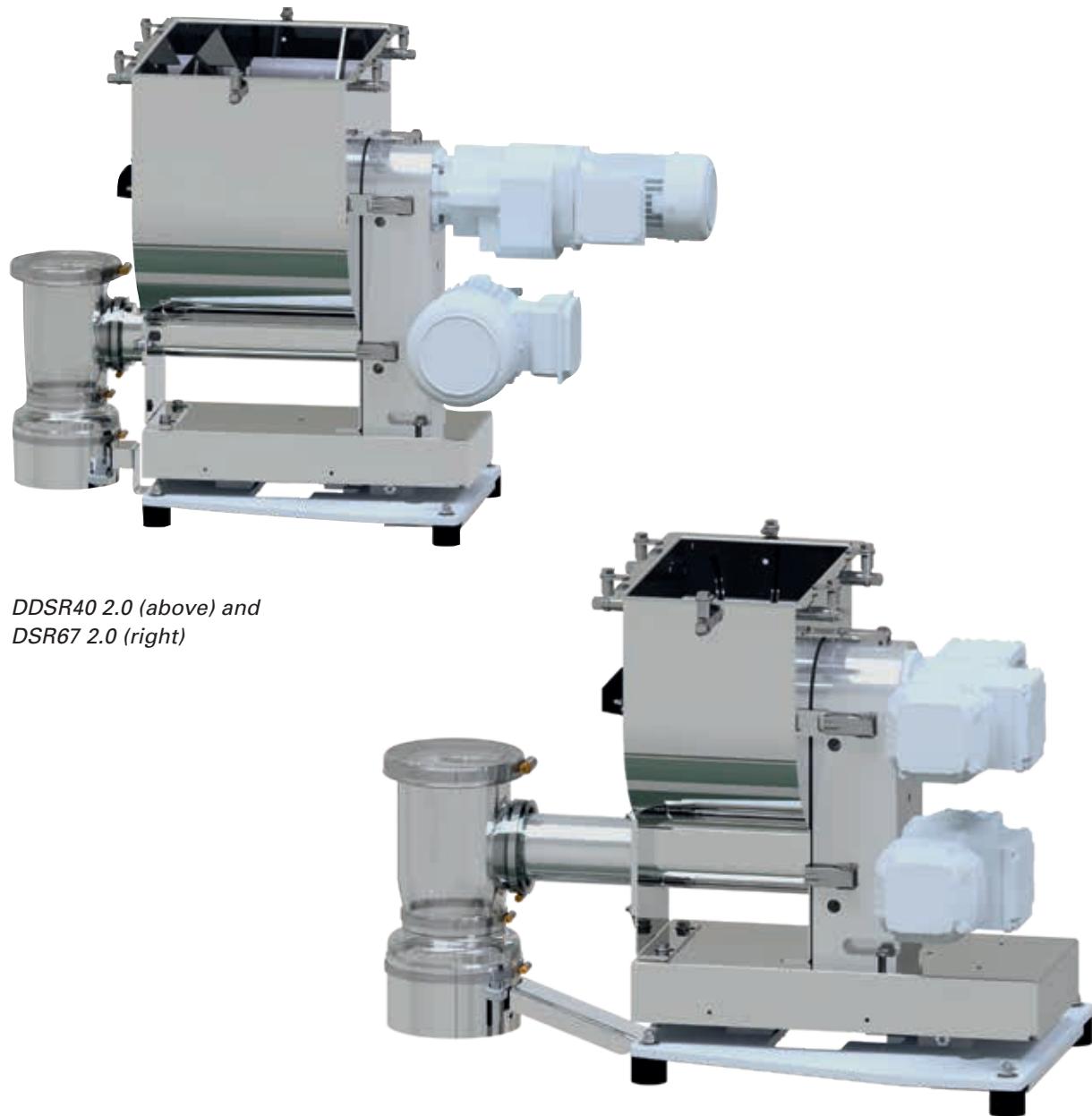

DDSR40 2.0 (above) and DSR67 2.0 (right)

Today's manufacturing process often demand smaller lots sizes with minimum downtime. To meet these demands, feeders must be extremely reliable and have quick clean features. Brabender Technologie's engineering team have developed the generation 2.0 line of feeder to meet these requirements.

"Our modular equipment generation 2.0 has enabled us to start offering customized, purpose-specific feeders that are even more efficient than before."

**Jürgen Knez,
Head of Product Development at Brabender Technologie**

Matching modules

Two of our most popular low-rate feeders the DDSR20 2.0 and the DSR28 2.0 have been in version 2.0 production for many months. We will soon release the model DDSR40 2.0 twin screw feeder featuring self-cleaning twin concave screw which is ideally suited for poor flowing, sticky ingredients. In addition, the DSR67 2.0 single screw feeder which is used for normal flow to cohesive ingredient applications will be released.

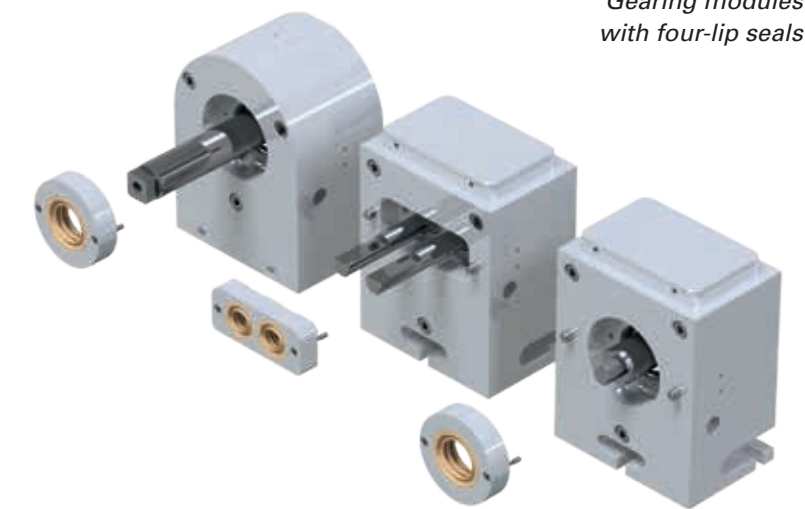

Gearing modules with four-lip seals

Jürgen Knez, Head of Product Development at Brabender Technologie, explains: "The new design approach for both these feeders focused on a perfectly matched modular design. The matching enables us to configure four feeder combinations, the DDSR40, DDSR40B, DSR67 and DSR67B version 2.0 using fewer standardized components."

Clean and compact gear module

All components are manufactured with a compact design gear module that is attached to the drive motors. Knez explains: "The modular concept allows the larger 'B' screw troughs to fit the

same predrilled baseplate as the standard models. This modularity can potentially allow field retrofits between models."

The DDSR40(B) 2.0 models now feature a clean and quiet drive belt technology custom manufactured for Brabender Technologie. These drive belts now allow the twin screw gearbox to operate without lubrication eliminating maintenance while increasing lifetime.

This generation 2.0 design also eliminates the need for chains, chainguards, bearings and inter-

mediate plates and couplings further simplifying the feeder. The gear modules operate with less noise, weigh less, and can be combined with both conventional AC motor technology and smart servo motors.

Knez summarizes: "The modular design allows the gearing units of all these feeders to be quickly and easily changed. They can be easily removed and replaced. This flexibility enables the customer to switch between large and small models or from single to twin-screw versions."

Removable hopper with user-friendly quick release fasteners

In the new modular concept, the screw hopper is located at the front edge of the scale. "This means that the screw trough can now be easily removed from the front of the feeder, similar to the smaller DSR28 2.0 and DDSR20 2.0 versions. Feeder accessibility has been greatly enhanced and end users benefit from the ease and speed of cleaning components that come into ingredient contact," says Jürgen Knez. What also helps are the screwless connections on trough, hopper and lids that reinforce this user friendliness. Knez explains: "We have created special captive fasteners for these hopper connections. The hopper fasteners are only rotated 90 degrees with a one size tool to loosen the connection. Everything remains in place so operators no longer have to hold loose bolts and nuts in their hands and are able to remove the hopper very easily."

Visual check saves time

Fully transparent, dustproof outlet tees, which are made of food-grade PETG and manufactured exclusively for Brabender Technologie, are installed on all standard and B-type feeders. This hard plastic is characterized by its high transparency and shatterproof construction enabling the operator to perform visual checks inside the screw tube.

Downspout

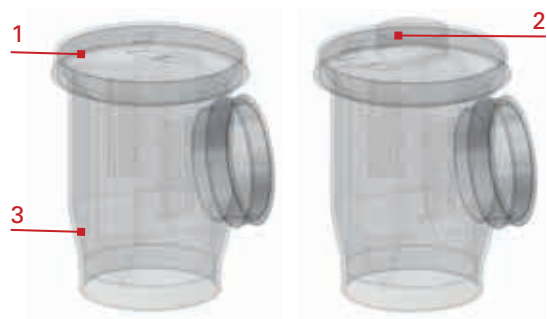

- 1 Silicone cover
- 2 Silicone cover, filter bag connection
- 3 Downspout, material: PETG hard (highly transparent)

Overview of Enhancements

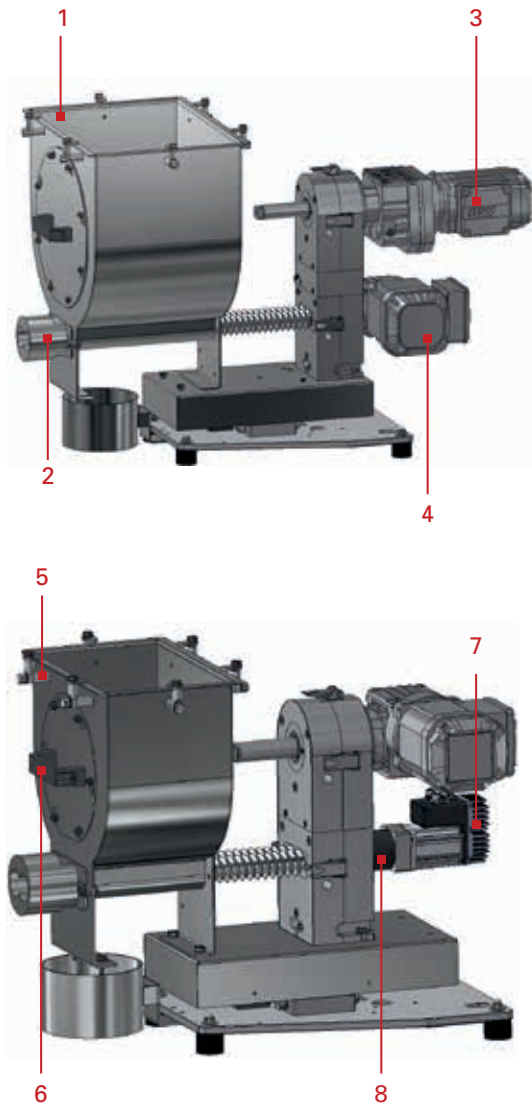

- 1 Removable hopper
- 2 Precision screw tube on the DDSR40
- 3 Agitator and screw motor made by the same manufacturer (SEW/Nord)
- 4 AC-IE3 motors
- 5 Screwless hopper, bin and cover connectors
- 6 Inspection aperture on standard type
- 7 Servo motors on standard and B-type feeders (standard option)
- 8 Standard installation position -100mm

Rapid seal change

Changing rotating shaft seals has also been made considerably easier by designing a screw trough that can be removed from the front. "A new seal can be installed in five minutes," Jürgen Knez tells us. Depending on what the customer requirements are, there are a large number of different seal types and designs available, including ATEX, food or pharma applications. An added feature of the 2.0 version are visual indicators in the bottom and top sections of the gear block assemblies to alert operators when seals need to be replaced which reduces the possibility of gearbox or motor damage.

Available servo motor

With this version 2.0 launch, we will be able to offer "smart" servo motors on all models. This servo motor has the added benefit that when compared to normal frequency-controlled AC motors, they have a much wider speed range and have full power available even at low rpm. The need to change screws and screw tubes can now be eliminated reducing downtime. At lower speeds, ser-

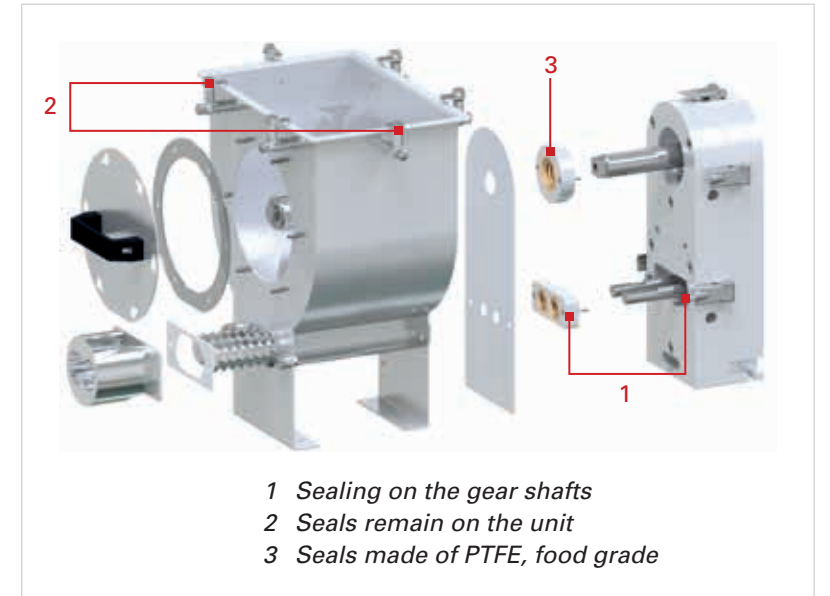

- 1 Sealing on the gear shafts
- 2 Seals remain on the unit
- 3 Seals made of PTFE, food grade

vo motors can start close to full torque, and even in high torque conditions they continue to have excellent speed control. Moving forward, this new generation will only feature Efficiency Class IE3 motors AC motors.

Conclusion: modular, customized, and flexible

The version 2.0 feeders will also feature reduced lead times due to the ability to stock additional standard modular components. This modularity also increases manufacturing flexibility if changes are made during the manufacturing

process. The redesign combined with recent load cell technology development allows us to bridge the gap between the "smaller" DDSR20 2.0 and the "larger" DDSR40 2.0 in terms of performance and feed-rate. Jürgen Knez explains: "This enhanced design approach has enabled us to start offering customized, purpose-specific feeders that are more effective than previous generation." Brabender Technologie will continue to develop its full product portfolio to align with the generation 2.0's modular concept. ■

i LOOKING FOR MORE DETAILED INFORMATION?

Click here for product pages:



@ CONTACT

Jürgen Knez
 Head of Product Development
 Brabender Technologie

 Phone: +49 203 9984-0
 Email: jknez@brabender-technologie.com

Discharging series: BAV | BagDumper | **SiloTray** | BagMaster

SiloTray

Keeping the flow

The Brabender SiloTray reliably and completely discharges poor-flowing ingredients at high rates from silos and bins. This is accomplished by linear vibration and a customized baffle design.

The SiloTray is attached directly to the silo or bin and acts as a discharge aid.



Costly production downtime often occurs once a bridge or rathole has formed above the outlet of a silo or bin. Michael Katzbach, responsible for spare parts and aftersales service at Brabender Technologie, is familiar with the problems associated with discharging bulk materials: “When bridging occurs, the bulk material gets wedged in the discharge hopper, meaning it can no longer flow on its own and an ingredient bridge is formed.” It is influenced by a number of material factors such as internal friction, grain size and shape. Its moisture content, kinetic friction between the ingredient and the hopper wall, and the bin shape are also important factors. Michael Katzbach explains: “If a rathole forms, the adhesive forces of the bulk material on the bin wall are too high. This results in an ingredient build-up from the wall to the middle of the bin, meaning that only the column of ingredient located above the outlet flows. This rathole significantly reduces the silo’s useable capacity.” This effect is also influenced by the properties of the bulk material and the smoothness of the bin’s inner wall.

Vibration ensures consistent bulk material discharging

The SiloTray can prevent ratholing and bridging. Two electromechanical vibrators (unbalanced motors) mounted to the cone exterior, work together with a suspended subassembly to create a linear motion. “These linear vibrations improve the flow of the bulk material and ensures ‘first in – first out’ discharge. This non-compacted discharge can be fed into downstream volumetric and gravimetric screw feeders or conveyor systems,” Michael Katzbach states.

The SiloTray also prevents uncontrolled flow with its unique vibration technique. In addition, it uniformly distributes the material weight in the bin. The SiloTray is ideally suited for granules, pellets, flakes, fibers and chips as its vibration technology does not use internal agitation therefore allowing gentle discharge.

Main components

The SiloTray is attached to the discharge of a silo/bin and is comprised of: An outlet cone with a mounting flange ring and integrated linear baffles.

i SiloTray

The SiloTray discharge aid improves flow of any bulk material and ensures that the product can be discharged in a non-compacted form from a bin or silo on a ‘first in – first out’ basis and is guided into downstream processes.



Two force adjustable electromechanical vibrators are mounted on the cone exterior. The cone assembly is isolated and suspended from a bin mating flange by flexible hanger rods and connected with a dust tight flexible sleeve. The bin mating flange is supplied loose and field welded to the customer bin or silo by others. This assembly forms a robust structure ensuring uniform distribution of the dynamic vibration forces.

By adjusting the vibration force and speed, the ingredient flow rate can be regulated. When flowing, the ingredient moves between the linear baffles into the cone and is guided to the SiloTray outlet.

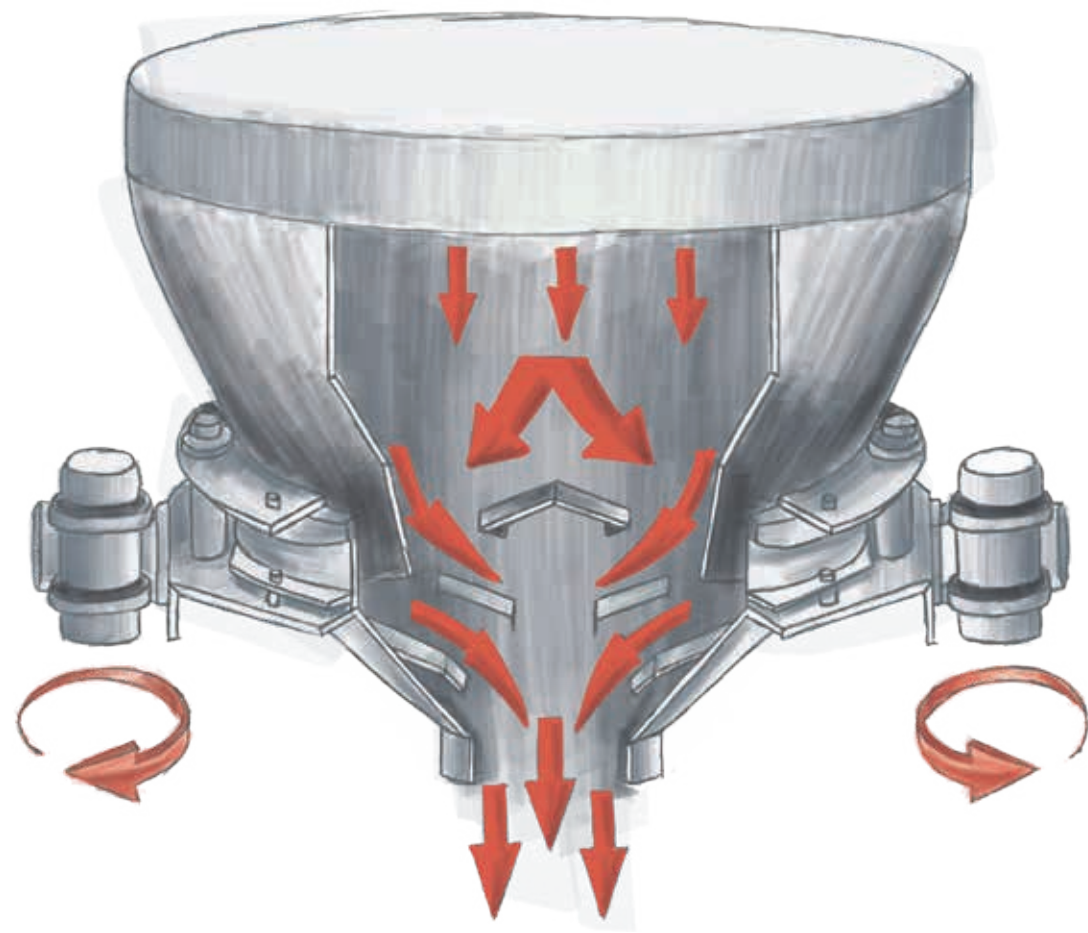

Two electromechanical vibrators (unbalanced motors) are fitted to the exterior causing the suspended cone to vibrate horizontally.

In combination with a feeder

The SiloTray can be used in conjunction with a feeder in applications where precise ingredient flow is required. In this combination, the SiloTray pre-feeds the feeder below with conditioned ingredient. The SiloTray flow rate can be regulated by adjusting the vibration and force levels.

“The feeder and SiloTray are matched to optimize system performance. These devices are simultaneously started and stopped. A flexible connection is used between the two devices to prevent vibration transmission to the feeder. If required, a shut-off valve can be used to prevent unwanted ingredient flow,” spare parts expert Katzbach explains.

Options and accessories

There are many options available for the SiloTray. For example, load cells and controls can be mounted on the bin which allows level measurement of ingredient. This measurement is important when the SiloTray is used to refill a loss-in-weight feeder.

The SiloTray comes in four different sizes, ranging from 600 to 1500 millimeters in diameter. “This enables us to provide the customer with the correct device for practically all bins and silos,” the expert says. “While our standard versions offer a product temperature range of 0 to 45 degrees Celsius, both higher and lower temperature versions are optionally available.” Explosion-proof options that comply with

i TECHNICAL SPECIFICATIONS

Ambient temperature:	0°C to +45°C (32°F to 113°F)			
Humidity:	up to 85% without condensation			
max. vacuum [mbar, psi]:	190 (2.75)	165 (2.4)	185 (2.7)	125 (1.8)
max. pressure [mbar, inches Hg]:	500 (14.7)	330 (9.7)	250 (7.4)	200 (5.9)
product temperature:	0°C to +60°C (32°F to 140°F)*			
max. bulk density:	1.5 kg/dm ³ (93 lbs/cuft)*			
Steel ingredient contact surfaces:	1.4571 (316), 1.4301 (304) or R-St27-2 (mild steel) (primed) polyurethane*			
Sleeve and outlet:	steel or stainless steel, galvanised or painted			
Non-contact components:	3000 min ⁻¹ (50 Hz); IP66; ISO-class F; (60Hz, Class II, Division 2, Group F&G)			
Unbalanced motor:	AC 230/400 V (110VAC/460VAC) – 50 or 60Hz**			
Power supply:	<70 dB in accordance with DIN 45635			
Noise level:				

* other options upon request

** 3 phase motors are designed for a power supply of: 230/400 V, 50 (60) Hz, and for the operation in TT networks, TN networks or networks with earthed neutral conductor. For different networks changes are necessary.

Regulation 2014/34/EU (ATEX) are also available.

The SiloTray can be fitted with a gate or butterfly valve to control the loss-in-weight refilling process. Various process connections are available including double wall outlets. “We also provide special solutions like flexible connections made of

silicone or neoprene or special motor voltages and frequencies,” Michael Katzbach explains. “The SiloTray is ideal for controlled discharge of bulk materials in a non-compacted condition, with or without volumetric feeding, and at a defined and predetermined rate into the downstream process.” ■

“Discharging and Refilling” brochure

Find out more about our other discharge aids! Download our “Discharging and Refilling” brochure

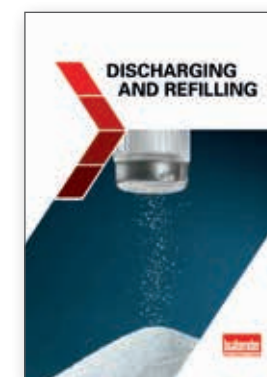

@ CONTACT

Michael Katzbach
Spare Parts Department
Brabender Technologie

Phone: +49 203 9984-0
Email: mkatzbach@brabender-technologie.com

Series: 8 hours with... the ShowTruck

It's Showtime

Exceptional times call for exceptional methods: in order to meet with and advise customers face to face during the pandemic, Brabender Technologie has enhanced its sales approach since May with the addition of the ShowTruck – a showroom on four wheels.

7 am. Departure from corporate headquarters.

You can clearly spot the new ShowTruck with its Brabender Technologie wrap from afar. Today, an appointment with a food industry customer is on the agenda. Inside the rolling showroom are various exhibits, which the team has matched to the needs and wishes of the customer. Exhibits on board today are loss-in-weight feeders including the FlexWall®Plus 40, the DS28 single screw feeder, and the DDSR20 twin screw feeder with smart motor.

On the journey, Bernhard Hüpmeier, Head of Business Development at Brabender Technologie, shares with us how he came up with the idea for the ShowTruck. "Personal and professional communication with customers and prospects at domestic and international trade fairs are an important part of our sales and service culture. Since the corona outbreak, we have not been able to participate in trade fairs and events and I have been exploring suitable alternatives. The 'ShowTruck' concept allows us meet local pandemic guidelines enabling inperson interactions again."



7:00 am



9:30 am

9:30 am. Arrival at the customer's location.

The ShowTruck with all its featured exhibits is good to go. Bernhard Hüpmeier just has to lift open the side door that releases the platform automatically with a simple touch of a button.

10 am. It's Showtime.

Using the on-board audio equipment, Bernhard Hüpmeier welcomes the customer's employees both inside and outside the truck and introduces them to Brabender Technologie.

10:30 am. Demonstration of the exhibits.

Interested individuals can take a closer look at our latest innovations including control systems and feeders while our

expert answers their questions. Today, our Hygienic Designs for food applications are attracting attention. However, versions of our equipment that are suitable for handling hazardous ingredients are also of interest.

11 am. Information session.

Films shown on a 55-inch screen provide information about a range of important feeding technology



10:00 am



10:30 am

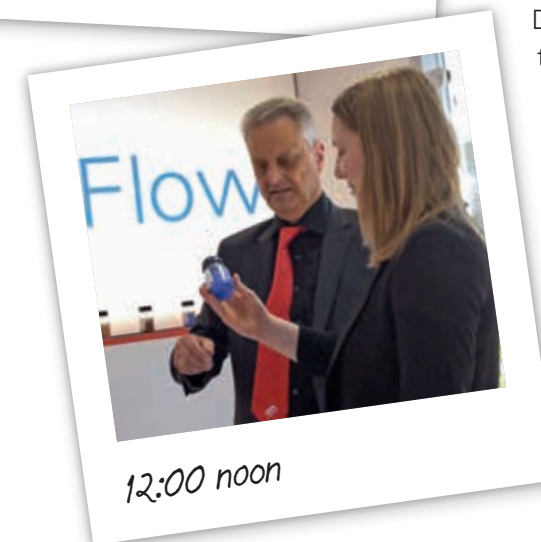

12:00 noon

challenges. For example, feeding solutions for poor-flowing ingredients like fibers or film offcuts – are an ideal complement to the in-depth conversations that Bernhard Hüpmeier is having with interested members of the customer's team.

12 noon. Individual conversations.

Stimulating conversations are held with existing and new contacts. These discussions enable Bernhard Hüpmeier and his sales team to draw valuable insights about the customer's needs and the technology required to meet them.

1 pm. Dismantling and return to base.

The Head of Business Development is more than satisfied with this

morning's work. "The ShowTruck offers the opportunity of face-to-face communications and the ability to share information about Brabender's state-of-the-art feeding technology, even in these exceptional times. This enables us to discuss customers' current challenges directly with our people. The customer we visited today took full advantage of this opportunity and we were very pleased to assist them in selecting the right feeder." ■

VIDEO

You can view the '8h with... the ShowTruck' video here:



CONTACT

Bernhard Hüpmeier
Head of Business Development
Brabender Technologie

Phone: +49 203 9984-0
Email: bhueppmeier@brabender-technologie.com

You can book your date via your Brabender contact or Bernhard Hüpmeier.

We look forward to meeting you in person at your premises!

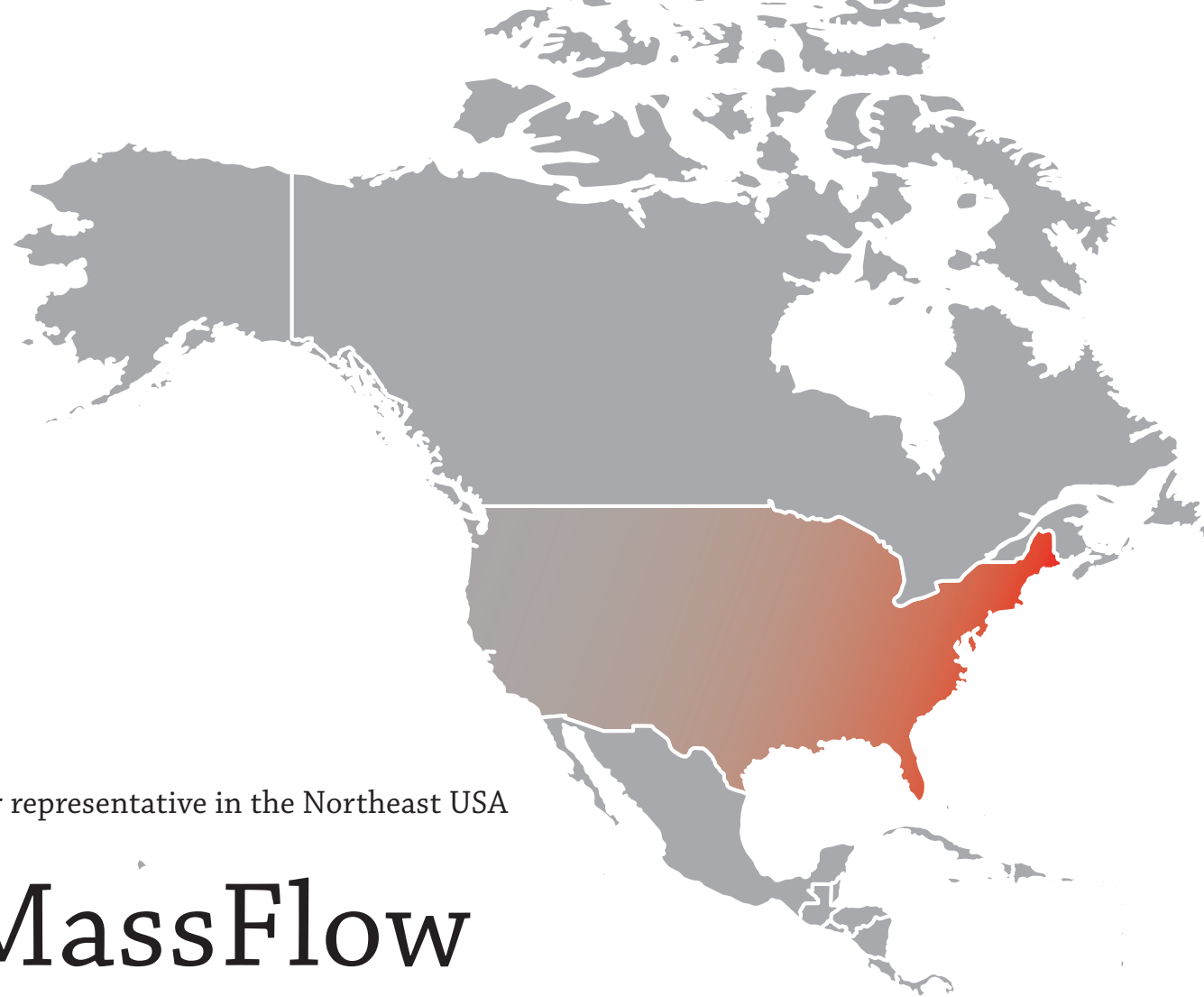

Our representative in the Northeast USA

MassFlow Solutions

MassFlow Solutions based on the US East Coast has been a knowledgeable and trustworthy partner to Brabender Technologie for almost 20 years.

When Doug Patridge founded MassFlow Solutions in 2002, Brabender Technologie was the first company to sign up with him. A close partnership has linked both companies ever since. Jim Rutter, who previously worked with Doug, joined in 2006. They have formed a committed and dynamic team for almost 20 years. Jim Rutter explains: "Doug Patridge is the owner, founder and president of MassFlow Solutions and handles the business and accounting sides of the company. I am responsible for marketing

activities, but we both have our own sales territories for various manufacturers of bulk materials handling systems within our region."

This is MassFlow Solutions

The agency covers eastern Pennsylvania, southern New Jersey, Delaware and Maryland. Doug Patridge adds: "I am responsible for the eastern part of Pennsylvania, while Jim handles Philadelphia and the surrounding regions, southern New Jersey, Delaware and eastern

Maryland." In addition to Brabender Technologie, MassFlow Solutions also represents various other equipment and component manufacturers from the bulk materials industry. This means that MassFlow Solutions can supply the majority of key components that customers require to process bulk materials. Furthermore, MassFlow Solutions offers its customers turnkey solution options, including system design, project management, installation services, customer-specific control systems and commissioning.



"Our focus has always been on dry bulk material handling equipment," says Doug Patridge. "Our customers operate in various industries – from plastics, food, pharmaceuticals, chemicals, feedstuffs through aggregates. We have positioned MassFlow Solutions to enable us to sell equipment and systems used throughout the bulk materials handling process. These include equipment for pneumatic and mechanical conveyors, sieving, mixing, milling, dedusting and packaging."

A personal touch for optimizing solutions

Jim Rutter and Doug Patridge closely advise and support their customers to find the ideal solution for their projects, equipment and facilities. By maintaining regular contact, they are able to clearly understand what equipment best matches the requirements in each application. "Although the pandemic caused us to use new digital communication channels, I still prefer to meet with customers in person and establish long-term relationships. Business relationships are always personal relationships and I am convinced that will remain the case," says Jim Rutter. Where less extensive service work is involved, both experienced repre-

sentatives occasionally even roll up their sleeves and lend a hand. Doug Patridge laughs: "We both have mechanical and electrical skills and have partnered with Brabender Technologie for so long that we can also handle simple service jobs ourselves. But as a rule, we always coordinate with the manufacturer."

A reliable partner on the US East Coast

These two sales representatives also invest the same personal passion in the relationship with Brabender Technologie as they do in maintaining contact with their customers. Here Doug Patridge has to smile again: "When customers tell me that they are merely treated as numbers by other feeder manufacturers, I love responding by saying: at Brabender Technologie that is not the case. Here everybody is treated as in a small family business." Jim Rutter adds: "The employees are very accommodating and professional. Given this level of support, it really is a pleasure to work with Brabender Technologie." However, the impact of the pandemic will need to be overcome in the near future in order to return to normal business operations. Both emphasize: "Irrespective of the current challenges, MassFlow Solutions remains a reliable and dynamic

team on the US East Coast. With our knowledge and experience of bulk material processes, we will continue to help our customers make the best decisions for meeting their requirements." ■



left: Doug Patridge, founder and owner of MassFlow Solutions right: Jim Rutter is responsible for marketing and sales



@ CONTACT

MassFlow Solutions Inc.

Doug Patridge
Geschäftsführer
Fogelsville, PA, USA

Telefon: +1 610 336-4180
www.massflowsolutions.com

News

A Successful Chinaplas 2021

For the first time since the pandemic broke out, Brabender Technologie attended an international trade fair in China from April 13 to 16, 2021. Chinaplas, one of the world's leading plastics and rubber industry trade fairs, was held in Shenzhen this year. More than 3,500 leading exhibitors from 41 countries showcased their innovative solutions to over 152,000 trade visitors from 85 countries in an exhibition space of 350,000 sqm.

Brabender Technologie welcomed many industry leaders to our booth to introduce our latest innovative, new products and technical solutions. Discussions focused on new developments such as the modular DDSR20 2.0, and our specialized FX and DS feeder lines. In addition, the Congrav®OP16 operating panel and high-performance CB controllers were also featured.

Two market trends emerged: feeder solutions for biodegradable polymers and manufacturing of plastic films (PET, PP, PI). Hongjun Yang, Vice President of

Brabender Technologie China, was delighted: "The quality of customer contacts was far better this year than in 2019. Potential customers stayed longer at the booth and their questions were specific showing a greater level of interest and commitment. Participating in Chinaplas 2021 has been very worthwhile. In the future, we will also promote our benchmark service quality and continue to work on optimizing our suite of professional services for new and existing customers and emerging industries such as battery manufacturing."



Fairs International 2021

At the following trade fairs you can meet Brabender technology around the globe in the second half of 2021 around the globe:

Equiplast 2021 Barcelona, Spain	14. – 18. 09. 2021 Hall 3, Booth B 51
Compounding World Expo 2021 Essen, Germany	29. – 30. 09. 2021 Booth A400
Fakuma 2021 Friedrichshafen, Germany	12. – 16. 10. 2021 Hall A6, Booth 6213
Compounding World Expo 2021 Cleveland, Ohio, USA	03. – 04. 11. 2021 Booth A203
Central Asia Plast World 2021 Almaty, Kazakhstan	11. – 13. 11. 2021 Booth B220
Plast Eurasia 2021 Istanbul, Turkey	01. – 04. 12. 2021 Hall 4, Booth 401A

Technical column

How sealed is your process?

When handling OEB hazardous powders, manufacturers require uncompromising workplace protection to insure operator safety and high product quality.

To meet these high standards, Brabender Technologie is committed to elevating our production standards of our next generation feeding systems to OEB levels.

In launching our DDSR20 and DDSR40 generation 2.0 feeders, we have created two pieces of equipment that are completely dust-tight. We have achieved this by using PTFE multi-lip seals on rotating screw and agitator shafts which have been proven in the recently developed DDSR20 2.0 and DDSR40 2.0 line of feeders. Our dust-tight design allows the trough to be conveniently removed to allow quick replacement of the seal insert. The seal insert is available in three or four lip configurations to meet food or ATEX requirements. Optionally we can provide air purged seals.

Hands free, quick release fasteners for the hopper and lid combined with a sealed sight inspection port for the PTFE lip seals provides an even higher level of OEB safety. These changes allow Brabender Technologie generation 2.0 feeders to be easily

adapted to specific process OEB level requirements.

The newly developed quick release fasteners with our one-piece cover and trough gaskets combined with a purged lip seal assembly meet OEB class requirements. We have incorporated this innovative sealing concept in most FlexWall® feeders. Here the standard single lip seal can be easily upgraded to a four-lip seal for food or pharma requirements.

Other new developments include making the popular vertical PETG outlets available on larger feeders such as the FlexWall®80, FlexWall®120, DSR67 and DSR103. The see through PETG allows visual checks into the screw tubes, allowing for easy troubleshooting. The outlets are now available in three sizes to cover our entire product range. PETG offers strong advantages: suitable for use in all industries, it is shatter-proof and features good chemical and thermal stability – a real winner!

We have also taken a leap forward in terms of energy efficiency. In the last few months, all the mo-



*Dr. Günter Kuhlmann,
CEO of Brabender Technologie*

tors in our product portfolio have been switched to a more energy efficient class IE3. The motors consume less energy and provide better performance. Servo motors launched in 2020 currently meet this efficiency class. ■

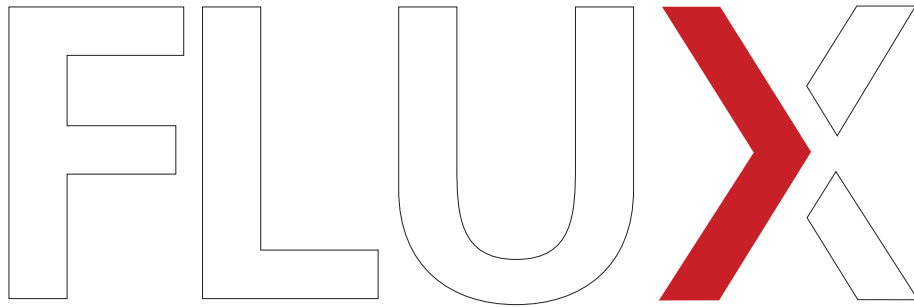

International

Brabender Technologie GmbH & Co. KG
Kulturstraße 49
47055 Duisburg, Germany

North America

Brabender Technologie Inc.
6500 Kestrel Road, Mississauga
Ontario L5T 1Z6, Canada

VR China

Brabender Technology (Beijing) Co., Ltd.
3rd F, B Section, No. 3 Workshop, 2nd Project
of Guanglian Industrial Park, No. 2 Kechuang
East 5th Rd., Opto-Mechatronics Industrial Park
Tongzhou, Beijing 101111, China

Russia

OOO "Service Vostok"
1-st Tshipkovsky per. H20
Office 16
115093 Moscow, Russia

India

Brabender Technologie GmbH & Co. KG
CJ-231, Ground Floor, Sector-II,
Salt Lake City, Kolkata-700091, India

United Arab Emirates

Brabender Technologie Middle East
P.O. Box 18139
Dubai, United Arab Emirates

Keep the Flow