

FLUX

The magazine for bulk ingredients technology

ONE COMPANY

The new NX Feeders
Made for both worlds

The first milestones
After the merger

BRUNO DAUTZENBERG

CEO

Kubota Brabender Technologie

HIDEKI SAIKI

CEO

Kubota Brabender Technologie

> editorial

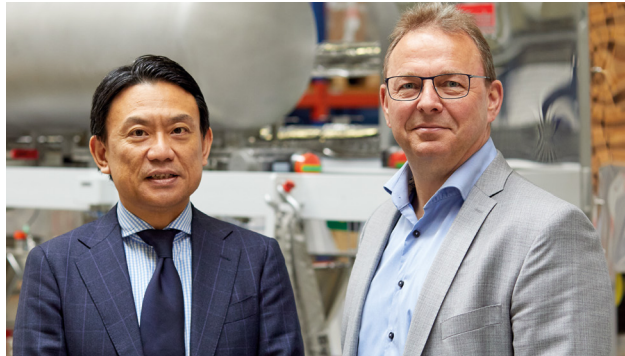

Dear readers, dear colleagues,

roughly a year has now passed since the Japanese technology and machinery manufacturer Kubota and the German feeder specialist Brabender Technologie merged to form the company, Kubota Brabender Technologie. In our first FLUX issue after the merger, we want to provide answers as to how effective our joint endeavors have turned out to be, both internally and in the perception of our customers in the past few months. This much in advance: after one year of collaboration, we can already look back on several gratifying achievements and a lot of positive feedback. This is because we have already managed to take some promising steps towards our objective of evolving as one company, both in technology and business terms.

A first tangible result of this is the new NX Feeder, which combines components from Japan and Germany and was showcased to a trade audience for the first time at POWTECH in Nuremberg. Read more about this on page 10.

The partnership with our customer Fette Compacting has resulted in our feeders being an innovative contribution to continuous tablet production state of the art. Read more on page 18.

And our colleague Carsten Dieckhoff reports from page 22 onwards about how eventful and insightful German-Japanese employee exchanges on site can be in practice.

We hope you enjoy reading this exciting issue!

Hideki Saiki and Bruno Dautzenberg



Kubota Brabender Technologie

IMPRINT

FLUX is the magazine for bulk ingredients technology from Kubota Brabender Technologie GmbH

Publisher:
Kubota Brabender Technologie GmbH
Kulturstrasse 49
47055 Duisburg, Germany
Phone: +49 203 9984-0
email@kubota-bt.com

Editorial Team:
Kubota Brabender Technologie GmbH,
C&G: Strategische Kommunikation GmbH
www.wir-verstehen-technik.de

Copyright and rights of use
of text and photos:
Kubota Brabender Technologie GmbH

www.kubota-bt.com

Edition no. 15
Release date:
December 2023

FLUX

> profund



- 04 Feeding in the pharmaceutical and chemical industries
State of the art
- 08 Technological progress
Current topics in feeding technology

> innovation



- 10 The new NX Feeders Made for both worlds
- 14 Digital information offering Fast and up-to-date

> usus

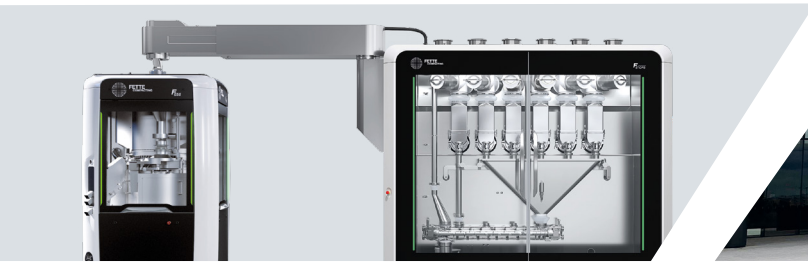

- 18 Pioneering product development partnership
The future of continuous tablet production

> global



- 22 On the road in Japan
"We were able to learn a lot"
- 24 After the merger
The first milestones

> persona



- 28 Understand and understood
One Company

> news



- 30 News
- 31 Kubota Brabender Technologie
at the POWTECH 2023
Connecting with a broad range of industries



Feeding in the pharmaceutical and chemical industries

State of the art

> Feeding systems play a key production role in the pharmaceutical, chemical and food industries. The pharmaceutical industry is one of the sectors in which particularly high demands are placed on feeding systems, due to product safety and legal requirements.

Sophisticated, high-precision technologies are used in many sectors today to ensure safe, high-quality manufacturing. Be it in continuous manufacturing or batch production, from standard to hygienic design, the aim is to ensure that high-precision, reproducible feeding delivers a high-quality product at the end of the process.

Different requirements, flexible solutions

By actioning customer requirements and complying with legal regulations, feeding technology also helps provide tangible customer benefits. Some industries are constantly evolving and always looking for new solutions and enhancements. This often involves significantly improved feeding accuracy, reduced waste through improved process control, and increased productivity throughout the manufacturing process.

Of course, the bulk materials that are processed have a major influence on the manufacturing process. These are also constantly being adapted, and therefore feeders need to be flexibly designed and built to enable them to adapt easily to these materials.

Materials and feeding quality

The bulk materials used often have different flow properties. Some powders have a particularly high density, others are very light, while others tend to bridge in the hopper or compact under vibration. However, the following is always key: absolute accuracy during feeding, easy cleaning of the feeder, and flexibility when it comes to adapting formulations and changing ingredients.

“We can even feed sticky and adherent products without interference.”

**Jürgen Knez,
Head of Mechanical Development
at Kubota Brabender Technologie**

From small quantities to large batches

Once again, it is pharmaceuticals containing often expensive, premium-quality active ingredients that place particular demands on feeding technology. Kubota Brabender Technologie provides equipment and accessories specially designed for the accurate feeding of small quantities, as frequently occur in the pharmaceutical industry. After all, consistently reliable, accurate feeding is and remains the be-all and end-all in pharmaceutical production. Be it for small batches or large quantities, all Kubota Brabender Technologie components feature high-quality workmanship and comply with the applicable standards and guidelines of relevant institutions.

Cleanliness and Hygienic Design

Kubota Brabender's feeders are extremely easy to clean and have special safeguards to avoid contamination. This so-called hygienic design includes smooth stainless-steel surfaces, non-porous, full-penetration, smoothed weld seams, and radial





Feeding a wide range of materials

edges. Modified geometry eliminates cavities in the equipment, and only FDA-compliant materials, such as high-quality stainless steels, are used for components that come into contact with the product. These Hygienic Design feeders are easy to disassemble; for example, screws and screw tubes have quick-release fasteners.

From theory to practice

The final certainty as to whether a feeder really meets all the customer's requirements is provided by the practical test. At Kubota Brabender Technologie, this test can be carried out in a test lab on request. In Duisburg and at locations in Canada and China, we carry out feeding and discharge tests with the relevant original bulk material. And thus ensure maximum possible safety and practicality before a new production process even begins. ■

i FLAGSHIP PROJECT WITH FETTE COMPACTING

The Fette FE CPS is a tablet production gamechanger

Through their collaboration on the new Fette CPS feeder, Fette Compacting and Kubota Brabender Technologie have provided a clear response to the question of what is state of the art in continuous tablet production.

From the very beginning, the new FE CPS aspired to be the continuous tablet manufacturing process pioneer.

Time will tell whether the FE CPS has what it takes to be a gamechanger. Initial reactions and inquiries from the major tablet manufacturers have already been received.

Read more in this issue starting on **page 18** in the article: **“Pioneering product development partnership – the future of continuous tablet production”**.



CONTACT

Jürgen Knez

Head of Mechanical Development
Kubota Brabender Technologie

Phone: +49 203 9984-228

Email: jknez@kubota-bt.com



Technological progress

What feeding technology topics are currently being discussed?

In the feeding technology segment, we are currently experiencing a phase of intensive technological progress, with numerous trends emerging simultaneously at various levels. The industry cannot afford to stand still, given increasingly complex processes and regulations. After all, feeding technology can influence aspects such as quality, safety, and efficiency in most applications: from the pharmaceutical and chemical to the food industries.

Below, we have addressed some of the feeding technology topics now being discussed, described them and briefly summarized them for you both in terms of their technological significance and potential, as well as the role they play in product development at Kubota Brabender Technologie.

Continuous manufacturing

Continuous manufacturing is one of the most significant developments in tablet production and is revolutionizing the way tablets are made. Some of the key trends in the development of this production process show how and by which parameters continuous manufacturing is driven.

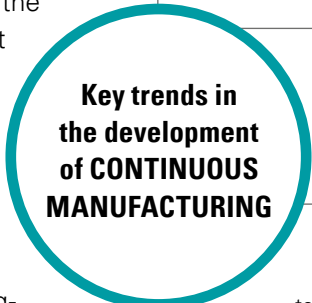

Key trends in the development of **CONTINUOUS MANUFACTURING**

PROCESS INTEGRATION

Continuous manufacturing integrates different process areas, such as mixing, pelletizing, drying and compressing into a single continuous process. This enables continuous, efficient production processes, reduces the need for intermediate storage and minimizes the divergences that we are familiar with in batch-to-batch production.

REALTIME QUALITY CONTROL

Continuous manufacturing enables realtime monitoring and control of critical quality aspects.

FLEXIBILITY AND SCALABILITY

The continuous production process allows rapid adjustments to production quantities, product formulations and other process parameters. This makes it easier to respond to changing requirements and reduces equipment costs for production facilities.

SUSTAINABILITY

Continuous manufacturing is also valued for its environmental benefits. This is because reduced divergences and higher process efficiency lower material and energy consumption and therefore negative impacts on the environment.



“In continuous manufacturing terms, effective interaction between electronics and mechanics has enabled us to map a reliable and highly accurate continuous process that is on par with the batch process.”

**Jürgen Knez,
Head of Mechanical Development at Kubota Brabender Technologie**

**OEB
(Occupational Exposure Bands)**

To protect users effectively in their workplaces, occupational exposure limit requirements in production facilities have rightly increased in recent years. OEB is a classification of dust exposure used for safeguarding occupational health to classify the degree of potential exposure to hazardous substances.



DDSR20 2.0 OEB

OEBs consist of a scale ranging from OEB 1 to OEB 5, indicating the higher risk of exposure in ascending order.

Kubota Brabender Technologie is one of the first manufacturers in the market to offer a feeder with OEB certification: the DDSR20 2.0 OEB. The DDSR20 2.0 OEB was developed especially for feeding in pharmaceutical applications or handling hazardous materials, such as in battery manufacturing.

Easy cleaning and Hygienic Design

Increasingly smaller batches, faster product changeovers and shorter intervals: nowadays, feeding equipment must meet many requirements. The aim is to reduce equipment and system downtimes to a minimum. Therefore, they should be quick and easy to clean and minimally susceptible to malfunctions. The developers of Kubota Brabender Technologie's new equipment generation 2.0 have factored this in and come

up with a modular concept for easy disassembly and optimum accessibility. Jürgen Knez, Head of Mechanical Development at Kubota Brabender Technologie summarizes the trend as follows: “In the future, more and more components and perspectives will be taken into account in the development and enhancement of feeding technology. It is no longer just about high-precision feeding. What matters are rapid process adaptations at the customer's site (cleaning and replacement of parts), operator safety (keyword OEB) and sustainability.” ■



KONTAKT

Jürgen Knez
Head of
Mechanical Development
Kubota Brabender Technologie

Phone: +49 203 9984-228
Email: jknez@kubota-bt.com

The new NX Feeders

Made for both worlds



After approximately one year as “One Company,” Kubota Brabender Technologie, its employees, and its target audiences now have a wide range of opportunities to assess the success of and prospects for their joint endeavors.

There are the employee exchanges in Asia and Europe, the understanding of each other’s values, and milestone and product development projects from the early days of collaboration, the outcomes of which provide a clear picture of the potential within



Further information

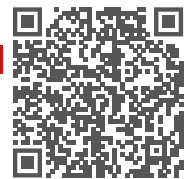

Work standard



the “One Company.” Because, in the end, everything comes down to whether it is possible to jointly develop better and more successful products for satisfied customers in the global market.

In launching the NX Feeder NXT45M, the aim was to showcase how the first German-Japanese product under the new brand Kubota Brabender Technologie is performing in the market at POWTECH in Nuremberg from September 26 to 28.

Now available in the European market too: the NX Feeder series by Kubota Brabender Technologie

As one of Kubota’s most important products in Japan, the CE-certified NX Feeders will now be sold

in the European market as well. One of the most innovative Japanese gravimetric feeders has been combined with proven Brabender technology. The base unit with the hopper comes from Kubota, load cells and servo motors from Brabender Technologie, and the entire sealing system has been newly developed. Overall, this is a successful product debut under the new brand umbrella, which is already generating high expectations.

And rightly so. Because the Japanese NX Feeders, with their negative wall angle hopper geometry that opens downwards and the diagonally aligned agitator, are considered groundbreaking in their home country and represent the company’s origins in the weighing & measuring sector.



NXT45M

The NXT45M is ideal for handling poor-flowing, sticky powders, as well as fibers and pellets at medium feed rates of 10–2,000 dm³/h (0.35–70.63 cuft/h).

It consists of the following main components:

- a screw trough with a negative wall angle
- a gearbox
- an inclined agitator in the screw trough
- a smart motor for the agitator
- a double screw in the screw tube
- a smart motor for the screw drive
- an add-on hopper for total bulk material storage of 110 dm³ (3.9 cuft).

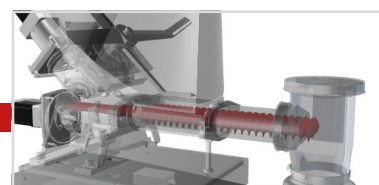

Twin screw



Smart motors

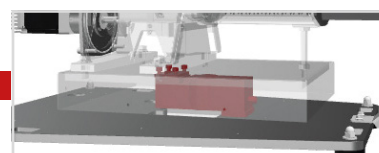

Load cell





NXT45M –
presented for the first time
at the POWTECH 2023 in Nuremberg

**Expanding the portfolio.
Broadening the market.**

The NX Feeder series is initially launching with two products: the NXT45M and the smaller version, the NXT26.

The DLS5/DLS6 or MD5/MD6 load cells for the gravimetric versions and the 0.4 kW servo motors for both devices are designed to meet CE certification requirements and make the newly designed feeders the right solution for a wide range of applications.

i **NXT26**

The smaller NXT26 feeder is ideal for handling poor-flowing, sticky powders, as well as fibers and pellets at low to medium feed rates of 1–700 dm³/h (0.04–24.72 cuft/h).

It consists of the following main components:

- a screw trough with a negative wall angle
- a gearbox
- an inclined agitator in the screw trough
- a smart motor for the agitator
- a double screw in the screw tube
- a smart motor for the screw drive
- an add-on hopper for total bulk material storage of up to 50 dm³ (1.8 cuft).



Further
information



Work standard

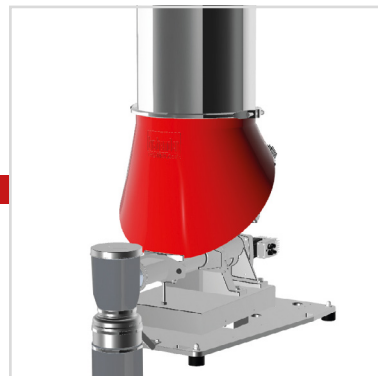

Screw trough with
negative wall angle structure



Agitator

Both feeders also appeal with a whole range of additional technical options that can be configured according to specific requirements. For example, pressure compensation or quick-release lock at the vertical outlet.

Nobuyuki Ozawa, responsible for the re-launch of the NX Feeder series, is more than satisfied with the results of this German-Japanese co-production: "Last year, we prepared the NX Feeder for the European market in Duisburg with a large team. Thanks to the unique geometry of the NX series, we can now feed even more challenging products and significantly expand our product range." ■

Our new
online magazine

FLUXdigital

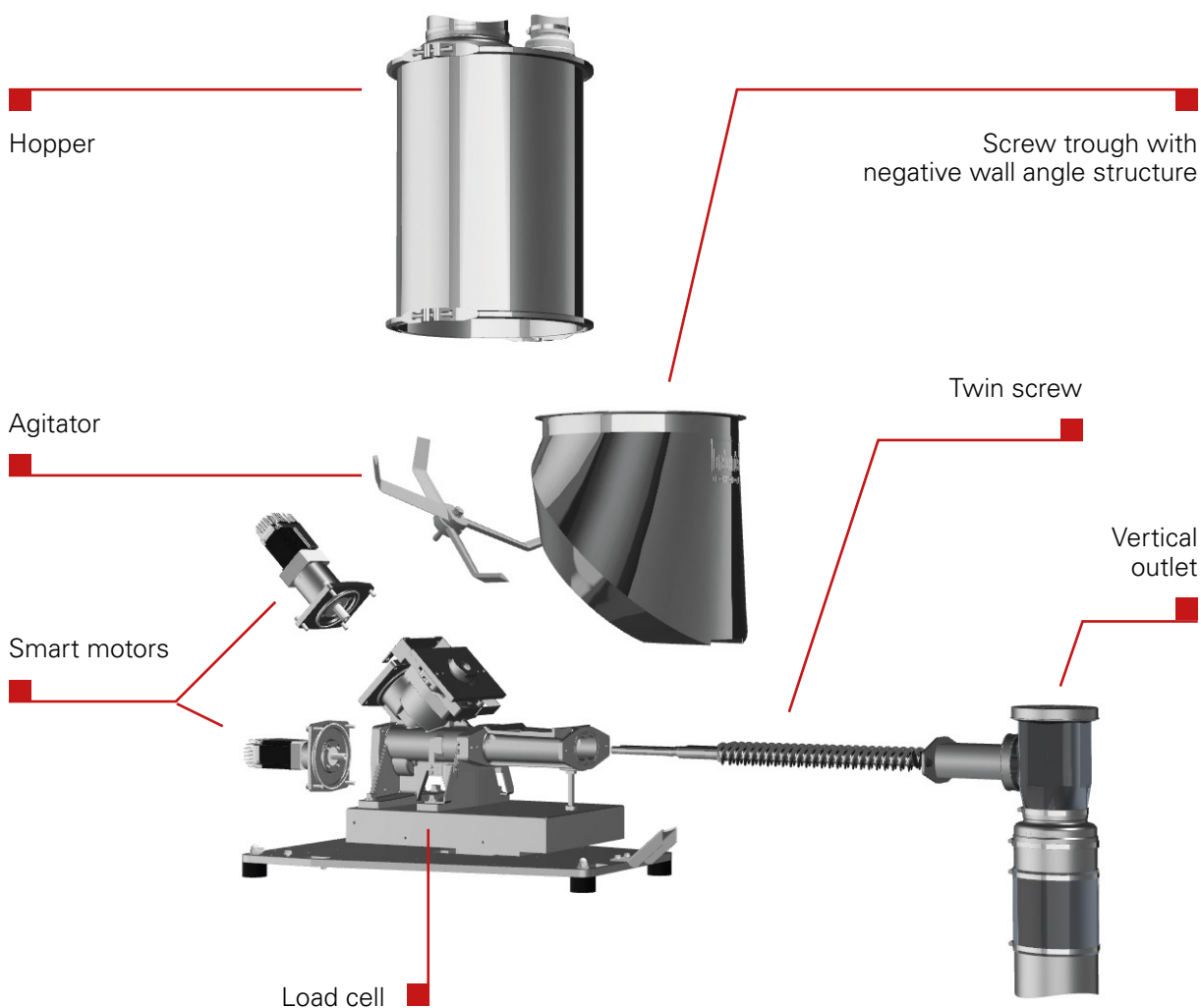

Kubota Brabender Technologie expands digital information offering for customers

Fast and up-to-date

> The FLUX Digital online magazine is the perfect complement to the familiar FLUX customer magazine.

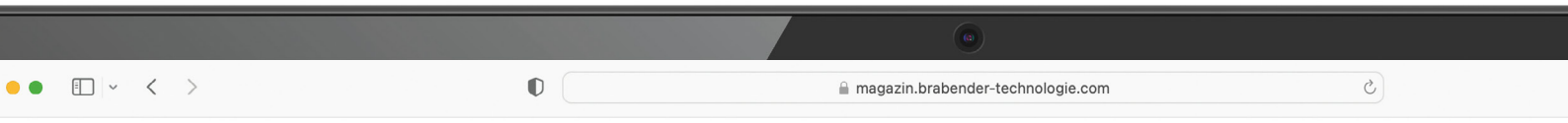

FLUX digital

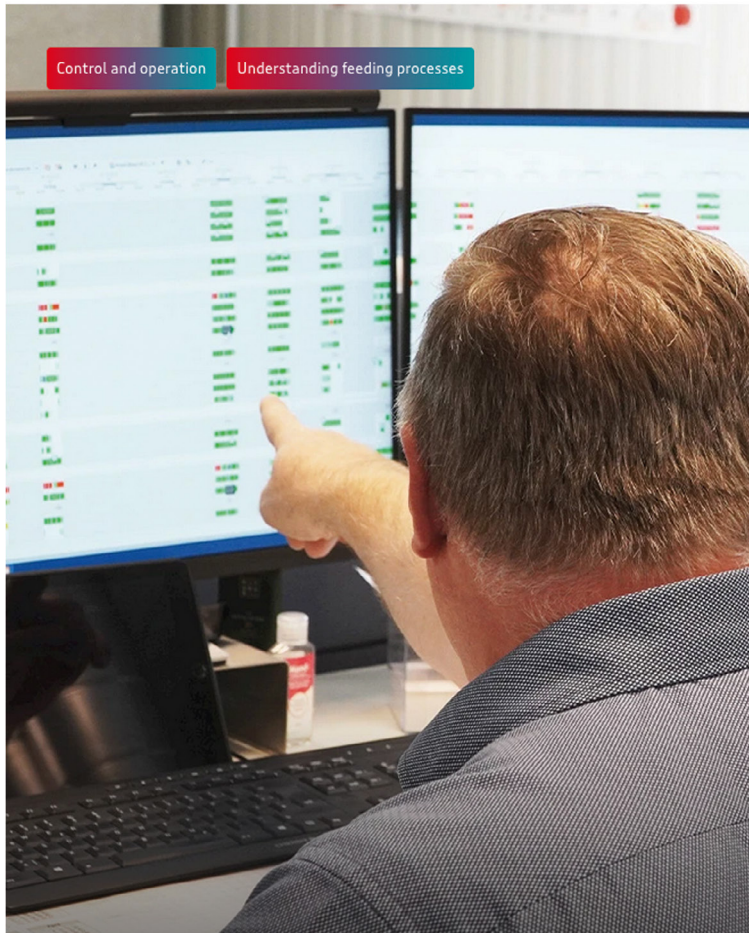

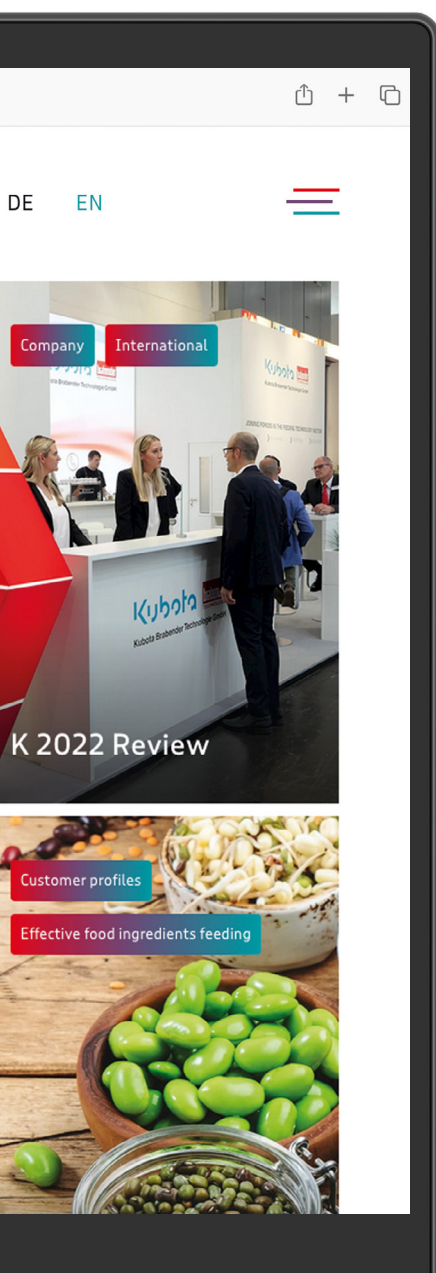

FLUX Digital – The online magazine for bulk materials technology

Kubota Brabender Technologie is expanding its digital information offering. With the launch of FLUX Digital, the online information medium that has complemented the print editions of the FLUX customer magazine since the beginning of 2023, Kubota Brabender Technologie's customer communication is set to become not only more digital, but also faster, more up-to-date, more versatile and more interactive. The declared objective is that the print and digital media should complement each other and create tangible added communication value.

> Up-to-date

> Interactive

> Image galleries

> Video integration

> Notes on related articles



Hybrid solution – the right medium for every customer

Get the best: FLUX Print and FLUX Digital

What exactly is this added communication value? First, the higher publication frequency. This automatically makes the digital sibling more up-to-date. Then there are the typical benefits that only an online medium can offer. The integration of videos, the opportunities to action a dialog offering, to use interactive forms and finally optimization for mobile devices. In terms of content, FLUX Digital scores points with its focus on one topic and can therefore update and enlarge on the print edition. In summary, one can say that FLUX Digital is not only an ingenious complement to the print edition, but as one of Kubota Brabender Technologie's online module and service sites, it also increases the appeal of the website. It therefore generates significant added value for our customers.

FLUX Digital, Test Lab and new Service site: the module sites at kubota-bt.com

The so-called Kubota Brabender Technologie module sites form the basis of an enhanced communication and service policy with which the company is

aiming to provide clear benefits to its customers in customer satisfaction and customer focus terms that go beyond the mere product level. A brand-new feature is the Service site, which summarizes all Kubota Brabender Technologie services at a glance, ranging from after-sales services to "retrofits" as a cost-effective alternative to purchasing new equipment. We also provide our customers with training courses that transform them into proven experts in the equipment they use. Here, we show them what they must pay special attention to when adjusting Kubota Brabender Technologie equipment. No matter whether in our training center or at the customer's site.

The Test Lab module site is intended to provide an overview of the equipment available in the Test Lab, especially for customers who are planning to visit. A Test Lab visit is an option for customers, who want us to test a new and very challenging product. During the visit, potential equipment combinations are then trialed and the customer can be there live.

Jennifer Salje, Head of Strategic Marketing at Kubota Brabender Technologie is satisfied: "The innovation boost that has resulted from the merger of our two companies not only impacts on sales and products. In marketing, too, we are well aware that we are now playing in a different, international league. Particularly as far as marketing and communications are concerned, this requires us to redefine and flesh out the customer focus of the new brand. Our proactive and open communication is therefore in line with our "Keep the Flow" philosophy at product level." ■

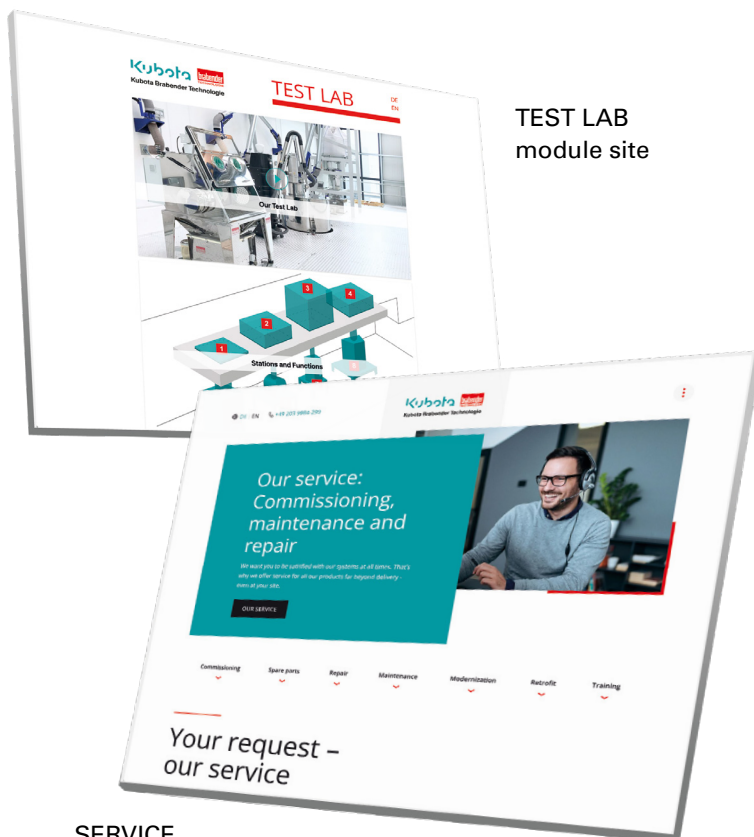

TEST LAB
module site

SERVICE
module site



OUR ONLINE OFFERING AT A GLANCE

Use the QR codes below and try out our module sites. One click and you are on the site of your choice.



> FLUX Digital



magazin.brabender-technologie.com/en/

> FLUX Print



Have a look at the older issues in PDF format.

> TEST LAB



technikum.brabender-technologie.com/en/

> SERVICE



service.kubota-bt.com/en/

Pioneering product development partnership

The future of continuous tablet production

> Continuous or batch feeding? Continuous or batch? Although continuous manufacturing technology and its benefits are familiar to the industry ...



The future of continuous tablet production

Although continuous manufacturing technology, with all its undeniable benefits, is familiar to the industry, so are reservations about it when it comes to deciding whether to use continuous or batch feeding, continuous or batch. In collaborating on the new Fette CPS feeding unit, Fette Compacting and Kubota Brabender have provided a clear answer to this key feeding technology question.

Continuous manufacturing rethought

From the very beginning, the new FE CPS aspired to be a pioneer in continuous tablet manufacturing processes. In contrast to previous solutions, the FE CPS makes no additional demands on installation sites and can be used in existing production spaces. Incidentally, the FE CPS is not only aimed



at pharmaceutical manufacturers. The machine continuously feeds and mixes up to 6 solids and therefore performs a function that can be reproduced on a wide range of different production lines.

The new feeding/mixing unit is based on Kubota Brabender Technologie's DDSR20 2.0, a twin-screw feeder featuring a modular concept offering easy disassembly and optimum accessibility. It provides a high degree of flexibility ranging from delivering even the smallest batches to high-volume production.

**Partners in product development:
Fette Compacting and
Kubota Brabender Technologie**

To develop the new feeding/mixing unit, which was of key importance to this project, Fette Compacting

initially had to find a partner who was willing to go down the same route and therefore share the risk of developing an entirely new product. Kubota Brabender Technologie finally came out on top in a 'beauty contest' involving almost half a dozen candidates.

"Our companies' basic requirements and in particular our ideas about what dimensions the new project would take on dovetailed right from the start", is how Nicolas Walter, (Continuous Manufacturing Application Specialist at Fette Compacting) explains the decision. And furthermore: "Kubota Brabender Technologie is an established feeder brand on the market and is equally willing to go down exceptional product development routes." Kubota Brabender Technologie was also able to fulfill another partner-



FETTE COMPACTING

Founded	1948
Headquarters	Schwarzenbek near Hamburg, Germany
Second production site	Nanjing, China
Specialist in	high-performance machinery for the pharmaceutical industry
Machines installed worldwide	over 5,000
More information	

ship requirement: the development of a so-called “Easy Clean” feeder, which enables the processing component of the end-product to be separated from the drive component. This allows processing components to be cleaned quickly and easily and, above all, independently of the location of the drive component.

Kubota Brabender Technologie was also able to score points in this contest on the strength of its experience and international operations, which enable worldwide service. Finally, the determination of all parties to get involved in such a flagship project played a major role, says Robert Feldges, who was responsible for the joint project at Kubota Brabender Technologie, in summary.

The FE CPS as a tablet production gamechanger

Looking back on this extremely effective partnership, as the spokespersons for Fette Compacting and Kubota Brabender Technologie both emphasize, the combination of a shared business perspective,

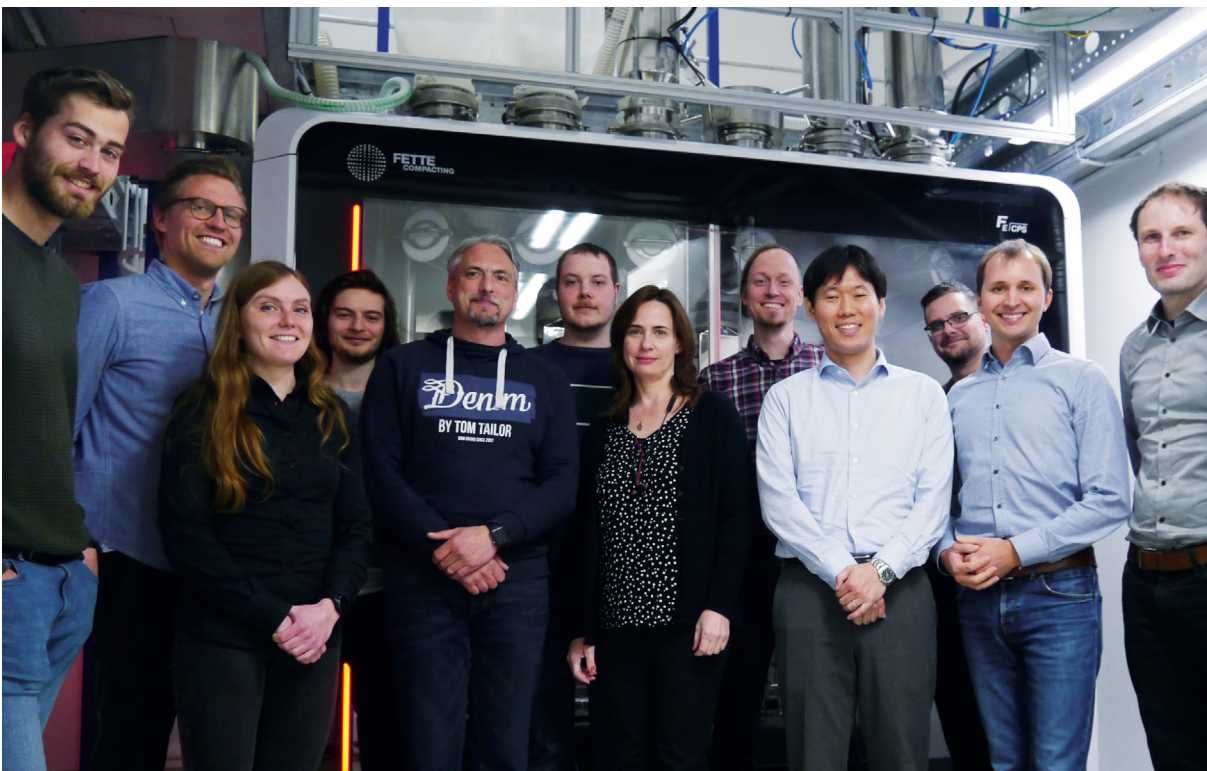

The Fette Compacting and Kubota Brabender Technologie product development teams met in Belgium at Fette Compacting. (f. l. t. r.: Sybren Laga, Wouter Grymonpré, Sofie Dupont, Theo Cominotto, Dominique Python, Lars Leyendecker, Daniela Wasiljew, Ingo Röpling, Yasuhiro Kishihata, Steffen Wölker, Nicolas Walter, Robert Feldges)

years of experience and product development expertise has enabled both companies to action a project that has what it takes to be a gamechanger. Initial reactions and inquiries from major tablet manufacturers have already been received.

In terms of looking beyond the project into the future of continuous tablet production, both parties rate the partnership as a success. That is because this future – both are convinced – will belong to a technology that is straightforward and easy to handle, compact and modular, yet smart and specifically adaptable to customer needs. And therefore, fully able to exploit all the efficiency potential of continuous tableting. Or as Nicolas Walter from Fette Compacting puts it: “With the new technology as represented by the FE CPS, we have been able to show that things can be done differently by applying a smart continuous manufacturing solution, even in the pharmaceutical industry.” ■

@ **KONTAKT**

Robert Feldges
 Head of Mechanics
 Kubota Brabender Technologie

Phone: +49 203 9984-260
 Email: rfeldges@kubota-bt.com

Feeds and mixes up to 6 solids continuously

No additional requirements for the installation site

> **Read more about the new Fette CPS feeding unit in FLUX Digital.**



The new Fette CPS feeding unit

On the road in Japan

“We were able to learn a lot”



It was not his first trip to Asia, Carsten Dieckhoff had already been to Asia and especially China several times on business, but it was his first trip to Japan. And there was a whole host of insights, impressions and experiences that made a great impression on him at the parent company and in Japan in general as well. In the second half of August, he and his colleague Markus Heine were there to learn what opportunities the German-Japanese merger offers, what can be improved and accelerated in Germany, and that – contrary to every cliché – digitalization in Germany is one step ahead.

The mission of Carsten Dieckhoff, production manager at the Duisburg location, and Markus Heine, deputy head of production planning, was to share ideas with their Japanese colleagues from Kubota Brabender Technologie on site in Osaka about production process optimization potential and to stop by Kubota headquarters as well. The aim was also to establish the criteria and KPIs for a regular sharing of information on productivity and product development – and not least to include Kubota Brabender Technologie's location in Canada. His conclusion: “It was a long journey; we learned a lot and saw plenty of potential to become much better together.”

The learnings began, as Carsten Dieckhoff recounts, as soon as they landed in Osaka, commonly known as the city where Kubota's headquarters are located, but less well known for its incredible size. Osaka, which forms the Kansai region together with Kyoto and Kobe, is one of the largest metropolitan areas in the world, with a population of around 19 million. Or as Carsten Dieckhoff illustrates the point: “If you look out from your hotel room on the 10th floor, all you see on the horizon are houses, no greenery.”



When the two were picked up from their hotel on Monday, they first went to the Kubota location, where they experienced the typical work routine of about 440 colleagues, all of whom, including the entire management team, were dressed in dark gray pants, light gray jackets, a baseball cap for indoors and a yellow hard hat for outdoors.

Different, disciplined, human

The key question, however, is how do people work contentwise in Japan and what ideas are there that can be taken home. The first thing Carsten Dieckhoff notices here is that there is no fully integrated digital production planning system in Osaka – unlike in Germany, where people work with GANTT and iPads, for example. The GANTT production planning system (more about this in FLUX Digital) is more or less operated manually in Osaka, by 6 employees.

For Carsten Dieckhoff, it is all the more surprising that production in Japan is significantly faster and better than in Germany. This applies above all to the extent to which process improvements are identified and implemented. There is a term for this, namely kaizen, and day-to-day work routines are scrutinized by a so-called kaizen team, which is exclusively out and about in the company to detect and eliminate deficiencies, waste (called muda in Japan) or errors. And that applies to all areas. For the two Germans, this was also the inspiration for



f. l. t. r.: Masayuki Kashu, Heine Markus, Dieckhoff Carsten, Tamura Kazutoshi

the first joint project that emerged from their visit to the location. At the beginning of next year, a kaizen team will come to Duisburg and, together with their German colleagues, will develop an assembly line that will be used in Japan and Germany. With the aim of ensuring production where the same standards and requirements apply at both locations and then for Canada as well.

Another initiative resulting from the visit by Carsten Dieckhoff and Markus Heine is the regular video call with Osaka. The sharing of the most important production KPIs in this call will then result in reports being drafted for the Production and later the Product Development teams. Work packages will also be defined and results reported. This regular contact will be accompanied or supplemented by employee exchanges at different levels. For example, two Japanese colleagues will be in Duisburg at the beginning of 2024 to help develop a joint product line, and the IT manager from Kubota/Japan is also expected in Duisburg next year with the aim of setting up paperless production. Also on the to-do list: a concept for operating software to be implemented after Kubota moves to Sakai, another city in the Keihanshin metropolitan area. Above all, however, Carsten Dieckhoff perceives that the Precision Machinery division of the Group, to which Kubota Brabender Technologie belongs, plays a special role for Kubota. Japanese colleagues are very keen on and are actively promoting so-called post-merger integration initiatives.

Agreeable colleagues and new friends

In addition to the gratifying outcome of having been on a successful trip that had taken him to Kubota Brabender Technologie as well as to Kubota's headquarters, Carsten Dieckhoff also takes the feeling of having made friends home with him. Because during the two weeks of his visit, he not only got to know very disciplined colleagues who take their

work seriously and are always eager to do things even better, even faster or even more efficiently, but also colleagues who quickly included the two Germans in their personal communication. Carsten Dieckhoff recounts: "They discussed soccer and private matters with Markus Heine during breaks and took us out for meals in some of the many local restaurants. There was not only a lot of work, but also a lot of laughter, and what I personally really appreciated was the fine sense of humor that the local colleagues have."

In this context, he has particularly fond memories of his translator Shirahase, who guided him through his entire Japan program in a competent and friendly manner. Because English is understood everywhere in Japan, as Carsten Dieckhoff has discovered, but it is spoken much less.

"Yes, I am convinced that we will benefit from each other," he emphasizes in conclusion, already looking forward to his next trip to Japan. ■



THE WORKING DAY IN OSAKA

- 08:30: a gong for gymnastics at work
- Morning meeting
- 12 o'clock: a gong to start the lunch break
- 16:50: a gong to announce the end of the day at 5 p.m.
- At 6 p.m. the plant is closed.
- Overtime is avoided whenever possible.



Impressions, results, and next steps after the Kubota Brabender Technologie merger

The first milestones

> The merger of Kubota and Brabender Technologie was completed almost a year ago. The newly formed company, Kubota Brabender Technologie, has already showcased jointly at trade shows, shared knowledge and experiences, and initiated a comprehensive integration process through workshops and various events to familiarize employees with each other's cultures.

It may still be too early to ask for results after just a few months of working together, but in a conversation, Bruno Dautzenberg and Hideki Saiki, the two general managers of the newly formed company, shared their first milestones, personal impressions, and plans for the future of the company and its markets.

The merger was accompanied by numerous strategic considerations, expectations, objectives, and visions.

These included the generation and utilization of synergies, increased influence in target industries such as the battery market, the expansion and optimization of the product portfolio, and the ultimate objective of becoming the number one manufacturer of gravimetric feeding systems. However, there are several internal tasks to be accomplished initially, including the integration of different cultures, standardization of processes, and the identification of relevant and marketable synergy potential.



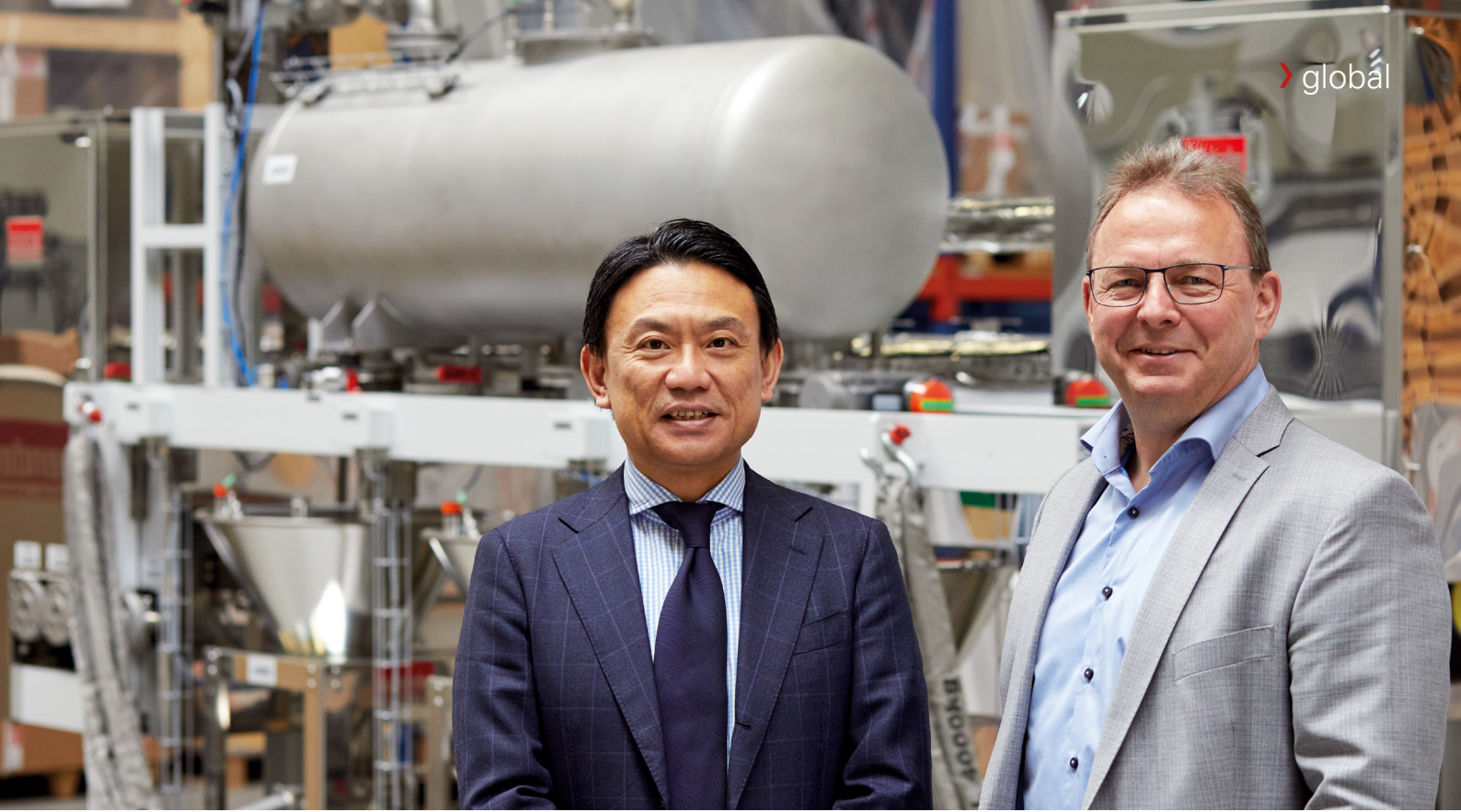

Hideki Saiki and Bruno Dautzenberg

So, how far along the path of integration are the two companies today?

“While western markets have accepted these new circumstances, the situation in Asian markets was somewhat more complicated,” says Bruno Dautzenberg. “This is also because feeding systems are just one of the many product segments in which Kubota operates. Market perception of the company is therefore more complex compared with Brabender Technologie, as we have always focused on feeding technology.”

During discussions at the CHINAPLAS trade fair in Shenzhen/China in mid-April, some of the people we spoke to were obviously much more surprised about the merger, than those attending the K plastics trade fair in Düsseldorf a few months earlier, Hideki Saiki confirms. Kubota is known in the Asian region not only for its agricultural engineering and construction products, but also for its feeding technology. However, the merger of the two feeding experts was initially viewed with a degree of ambivalence by some Asian customers.





The Kubota Brabender Technologie team at K 2022 in Düsseldorf, Germany

The regret at having one less supplier in the global feeding technology market due to the merger reflects the perception in the Asian markets. This reaction is, in part, due to the significantly different traditions of the two new partners. On one side, there is a Japanese company that has been in existence for 130 years and now encompasses various sectors under a global identity focused on food, water, and the environment. On the other side, there is Brabender Technologie, a German company founded in the 1950s, exclusively focused

on feeding, weighing, and discharging equipment for bulk materials and liquids, serving as a true example of quality “Made in Germany.”

Integration, customer focus, and premium products

The newly formed brand, Kubota Brabender Technologie, is primarily looking ahead, with integration being a key priority. The objective is nothing less than the establishment and development of a global premium manufacturer of feeding technology.

A significant impact on the Asian market should be felt within a timeframe of 3 to 5 years. New feeding technology solutions are to be developed particularly for Japanese customers, to enable the company to enhance its perception and appeal as a feeding technology specialist in Asia. When it comes to the stated objective of Kubota Brabender

“We will focus on both the satisfaction of our customers with our products and services and the numbers.”

Hideki Saiki,
CEO at Kubota Brabender Technologie

“We will enter the global markets side by side with our shared, enhanced and newly structured product portfolio.”

**Bruno Dautzenberg,
CEO at Kubota Brabender Technologie**

Technologie becoming the number one global competitor, Hideki Saiki emphasizes that numbers alone are not enough. “We will focus on both the satisfaction of our customers with our products and services and the numbers,” is how he describes his understanding of this objective.

An example of the company's commitment to product quality is the planned expansion of the product portfolio with the NX Feeder series from Kubota. The next step for this series is to obtain CE certification to make it compatible for the European market. In future, the NX series will be fully integrated into the Kubota Brabender Technologie portfolio. This will allow the NX series success story in the Asian market to be continued on other continents. Bruno Dautzenberg describes the entrepreneurial mindset behind this move. “We will enter the global markets side by side with our shared, enhanced and newly structured product portfolio.” He also emphasizes the premium concept behind it. “These measures will provide

clear answers to questions of product quality, customer satisfaction, and the future viability of our products.”

This product campaign is complemented by enhancements in Services and Sales, creating tangible added value for customers. Best quality only results from this combination of premium products and first-class service, and the

increased number of locations means better global service options. Customers benefit from greater accessibility and even more comprehensive support. ■



Understand and understood

One Company

Workshops for getting to know each other's cultures, language courses, employee exchanges – these and many other measures are dedicated to the major internal issue of integrating the two cultures.

Initially, the focus is on understanding each other's culture to facilitate integration and collaboration. It is about intercultural behavior, the convergence of German and Japanese cultures, which may seem different at first glance, but are not so different upon closer examination. In this process, Bruno Dautzenberg is particularly impressed by the discipline and seriousness of the Japanese colleagues, which, based on his previous experience, is especially evident in their shared meeting culture. "In meetings,

Japanese colleagues are always superbly prepared and provide precise information and proposed solutions, while we often see meetings as an opportunity to communicate about tasks. We tend to talk and gesture more, usually aiming to find a solution quickly, whereas colleagues from Japan approach meetings calmly and thoughtfully." Currently, five Japanese colleagues from different departments are working at the Duisburg location. They are expected to contribute to developing concepts together and

enhancing processes in areas such as production, product development, sales, and organization.

In general, Hideki Saiki is convinced that Japanese and German colleagues share many similarities regarding the seriousness and consistency with which they are approaching the transformation process ahead of them. "All employees, regardless of where they come from, take the ONE COMPANY motto very seriously, even if they approach it from different angles." To understand



these different approaches, it is also helpful to look at the history of the two companies.

The Kubota company slogan “For Earth, For Life.” encapsulates its social commitment to humanity and the environment, rooted in KUBOTA's origins, when it made significant contributions to the drinking water supply in Japan over 130 years ago through the production of water pipes. Today, this commitment has evolved into comprehensive global solutions for agriculture, water, and the environment.

With “Keep the Flow,” the Brabender tradition has developed a message that primarily aims to manufacture feeding technology products as reliably as possible.

Both leaders agree that the new company should build on the combination of values in both areas: social responsibility and product quality. And both Bruno Dautzenberg and Hideki Saiki are confident

that it is precisely these values that will provide a solid foundation for the new company. Social responsibility on one side, responsibility for reliable products on the other: the new company embodies the combination of these two value dimensions and fundamentally sees it as a matter of time for their integration to take effect.

Almost a year after the merger, this assessment reflects a courageous and motivated outlook for the future. ■

For Earth, For Life

Keep the Flow

News

The 'Werkstatt für angepasste Arbeit (WfaA)' in Düsseldorf



More participation in the world of work for people with disabilities, an extended workbench, capacity flexibility, and reduced throughput times for us: our relatively recent production partnership with Düsseldorf-based sheltered workshop 'Werkstatt für angepasste Arbeit (WfaA)' has only advantages for everyone involved.

Basic subassemblies are pre-assembled, terminal boxes and power supply subassemblies are produced and cable ends are customized for Kubota Brabender Technologie at the two sites in Reisholz (mechanical assembly) and Angermund (electronic assembly).

The WfaA is a very special kind of company. People with and without disabilities not only work together here in the fields of integration, rehabilitation, and advancement, but also see themselves as a reliable and skilled partner for clients from the business world.

We are delighted about this partnership and appreciate the sense of togetherness beyond the job itself.

Thoroughly persuasive

The FiberXpert, Mini Twin and DDRS20 feeders were exhibited for the first time at the N-EXPO and INTERPHEX Week Tokyo trade shows. Interest was substantial and shows that the performance data and customer benefits of these feeders appealed. It can be said with conviction that the Japanese market reacted positively to the showcase.



INTERPHEX Week Tokyo 2023



New Environmental Exhibition 2023 (N-EXPO)

Our new online magazine

FLUXdigital



International trade shows in 2024

You can meet our experts at these in-person trade shows in 2024:

CHINAPLAS 2024, Shanghai, China	April 23–26, 2024
NPE – The Plastics Show, Orlando (Florida), USA	May 06–10, 2024
PRS – Plastics Recycling Show Europe, Amsterdam, The Netherlands	June 19–20, 2024
SOLIDS, Dortmund, Germany	October 09–10, 2024

Kubota Brabender Technologie at the POWTECH 2023

Connecting with a broad range of industries



Insight into the product portfolio of Kubota Brabender Technologie

From September 26 to 28, process engineering experts from all over the globe came together at POWTECH in Nuremberg – and Kubota Brabender Technologie was among them. Once again, the processing trade fair attracted visitors and exhibitors from a large and diverse spectrum of sectors.

The diversity of the industries that come together at POWTECH holds special interest for Kubota Brabender Technologie. “Our product portfolio has the right high-tech feeding solution for virtually every application and bulk material,” says Managing Director Bruno Dautzenberg. “That means we are potential partners for all industries that process bulk goods. We just need to connect.”

Establishing and strengthening partnerships

As in past years, the trade show again allowed Kubota Brabender Technologie to strengthen its

relationships with existing partners – and to connect with new acquaintances from many sectors of industry.

Unveiling the NX feeder

POWTECH was also the stage for a special debut. Kubota Brabender Technologie revealed their latest solution: the NX series feeder. The article on pages 10 to 13 explains both what this remarkable feeder means for the company, and what it brings to manufacturing processes – namely innovative mechanical design, proven technology, and a constant, even flow of bulk material, including

sticky powders with poor flow characteristics.

Other exhibits

Kubota Brabender Technologie’s exhibits also included the company’s proven gravimetric and volumetric feeding systems, which provide the gold standard in a diverse range of manufacturing industries. Visitors showed particular interest in the Flexwall, a universal feeder ideally suited for all flowable materials, that featured a transparent hopper giving direct insights into its operation. ■



Interesting discussions with existing partners and new acquaintances from many sectors



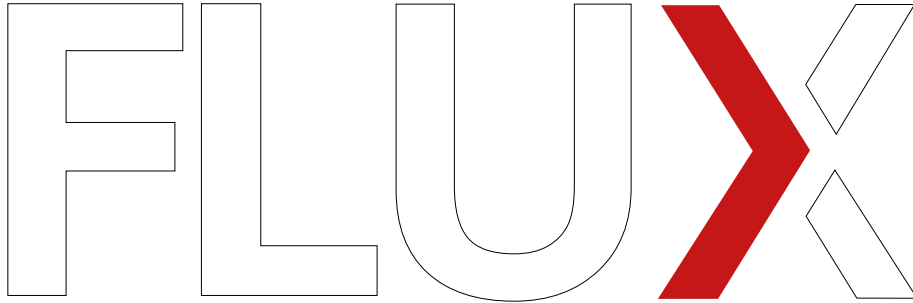

Kubota Corporation Headquarter

Kubota Corporation
Business Unit Precision Equipment
1 Chome-16-6 Tatsumikita, Ikuno Ward,
Osaka, 544-0004, Japan

Kubota Corporation Europe

Kubota Holdings Europe BV
Hoofdweg Oostzijde 1264
2153 LR Nieuw-Vennep, The Netherlands

**Kubota Brabender Technologie
Headquarter**

Kubota Brabender Technologie GmbH
Kulturstrasse 49
47055 Duisburg, Germany

**Kubota Brabender Technologie
North America**

Kubota Brabender Technologie Inc.
6500 Kestrel Road, Mississauga
Ontario L5T 1Z6, Canada

Brabender Technologie VR China

Brabender Technology (Beijing) Co., Ltd.
3rd F, B Section, No. 3 Workshop, 2nd Project of
Guanglian Industrial Park, No. 2 Kechuang East 5th Rd.,
Opto-Mechatronics Industrial Park Tongzhou, Beijing
101111, China

Brabender Technologie Russia

OOO "Service Vostok"
1-st Tshipkovsky per. H20
Office 16
115093 Moscow, Russia

**Brabender Technologie
India**

Brabender Technologie GmbH & Co. KG
CJ-231, Ground Floor, Sector-II,
Salt Lake City, Kolkata-700091, India

**Kubota Brabender Technologie
United Arab Emirates**

Kubota Brabender Technologie Middle East
P.O. Box 18139
Dubai, United Arab Emirates

Keep the Flow